

XTreme - EMS

Universal Engine Monitor

Operating Manual – English 1.01



Introduction

The XTreme-EMS is a compact universal engine monitor. The XTreme-EMS, which fits a standard 3 1/8" instrument panel hole, contains all the necessary functionality to replace several engine monitoring instruments.

All information is displayed in an easy to read format on a high resolution wide viewing angle 4.3" sunlight readable color display.

The XTreme-EMS' light weight, small size and high level of functionality makes it an excellent choice for all types of non-certified aircraft.

1 Features

Engine Monitoring:

- 1x Engine RPM display
- 1x Rotor RPM display
- 1x Manifold pressure display
- 1x Oil pressure display
- 1x Oil temperature display
- 2x Auxiliary analog channel displays (Pressure/Temperature/Current)
- 12 Channel EGT/CHT display
- 2x Fuel Flow display
- 2x Fuel Level display
- Special Rotax 912/914 engine monitor mode utilizing the standard built in Rotax NTC CHT probes
- Programmable maintenance timer for scheduled routine engine maintenance
- User settable Hobbs meter (password protected)
- Fuel range / endurance calculated from GPS ground speed. *Note (3)
- Supply Voltage display
- OAT (Outside Air Temperature) display using an external OAT probe
- Engine leaning feature
- Stopwatch timer
- Automatic / Manual flight timer
- RTC (Real Time Clock)
- Current monitor to measure charge/discharge currents. *Note (1)
- CO Monitor. *Note (2)
- Engine display screens are automatically configured to optimize screen space depending on what parameters are been displayed

Hardware:

- Powerful 32 bit ARM processor
- 4.3" high resolution 480x272, sunlight readable, wide viewing angle, 600 nits TFT LCD display
- LED backlight (brightness can be adjusted for low light flying conditions)
- Fits standard 3 1/8" aircraft instrument panel hole
- SD Card interface for data recording, user splash screens, checklists, graphic information pages, firmware upgrades etc
- 1x RS232 communication port (CO Monitor *Note (2))
- 1x MGL Avionics Airtalk communication port
- 1x MGL Avionics RDAC communications port
- 1x CAN communication port
- Rotary control plus 5 independent buttons for easy menu navigation and user input
- External alarm switch output for an external indicator lamp etc
- Support for an external GPS receiver
- Built in RTC (Real Time Clock)
- Wide input supply voltage range of 8 to 30V DC
- Built in voltage reversal and over voltage protection for harsh electrical environments
- Light weight design

General:

- Records maximum and minimum values of most displayed values
- Built in black box recorder – records all engine data and GPS data to SD card. Data can be exported to Google Earth, Microsoft Excel, etc.
- Includes a 1000 entry automatic flight log (Records start date&time, flight time, pilot number, Hobbs time and maintenance time)
- User configurable start up (Splash) screen
- Unlimited configurable checklists
- Unlimited configurable graphic information displays
- Automatic or manual local magnetic variation
- Dual menu system for quick item selection and user setups
- Sunrise/Sunset calculator
- Firmware upgrades via SD Card
- 1 year limited warranty

- (1) Requires optional MGL Avionics current monitor sensor
- (2) Requires optional CO Guardian CO detector
- (3) Requires external GPS receiver



2 XTreme-EMS Layout

2.1 Front layout

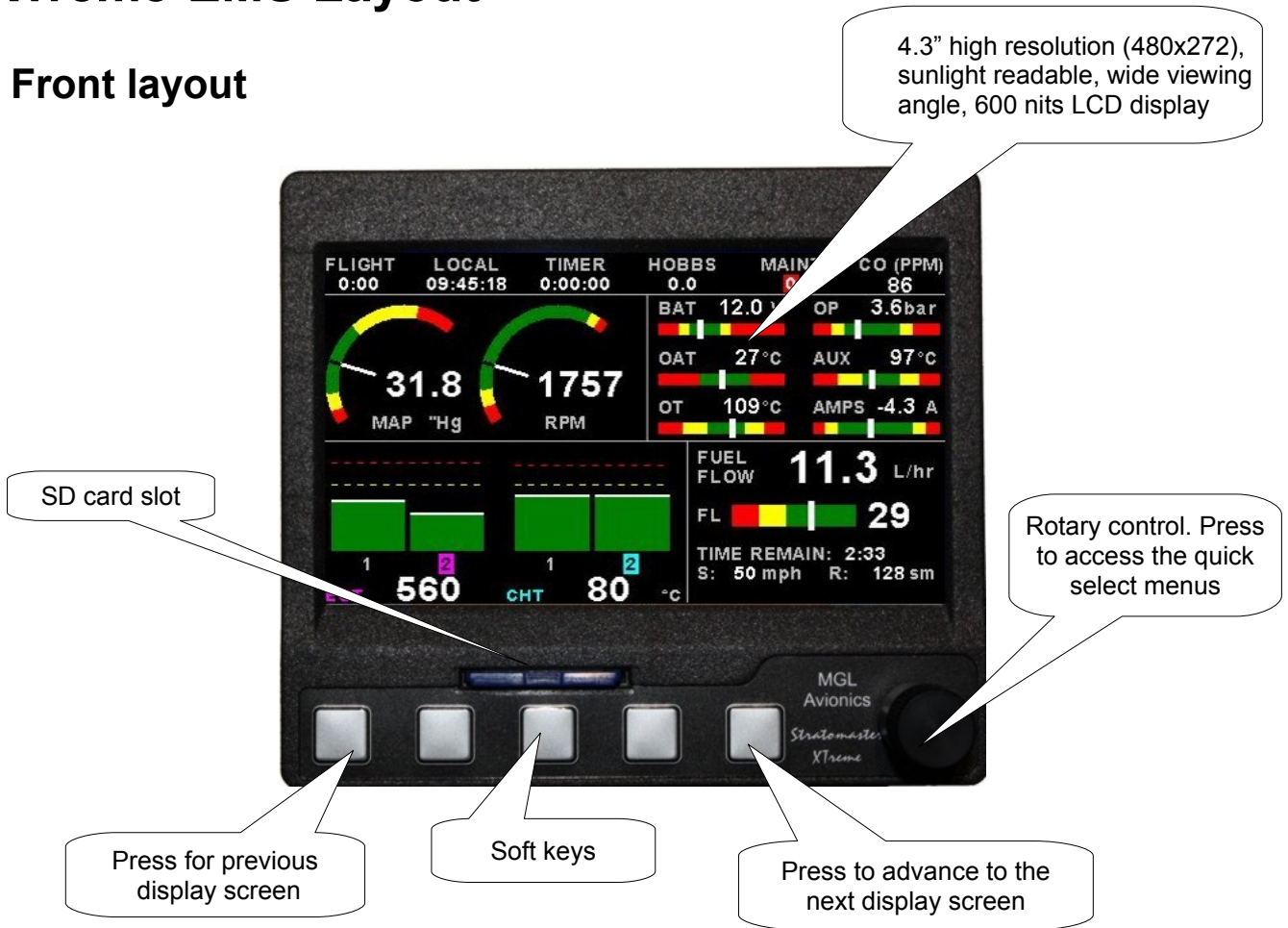

2.2 Rear layout

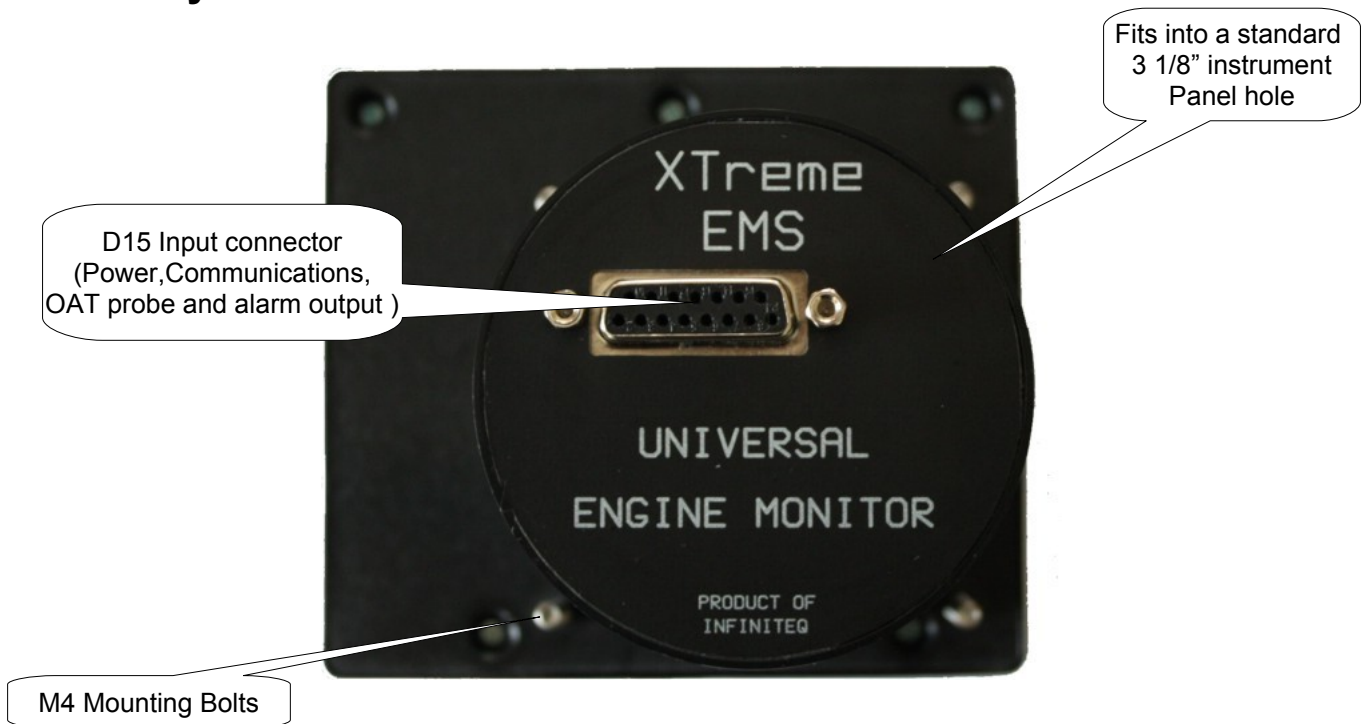

3 Display Screens

Press the left or right most soft keys to cycle through the display screens.

EMS DISPLAY

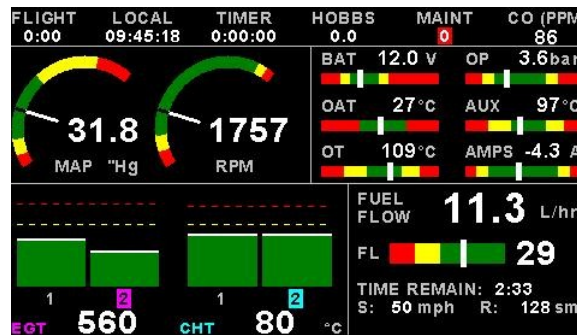

GPS DISPLAY (External GPS receiver required)

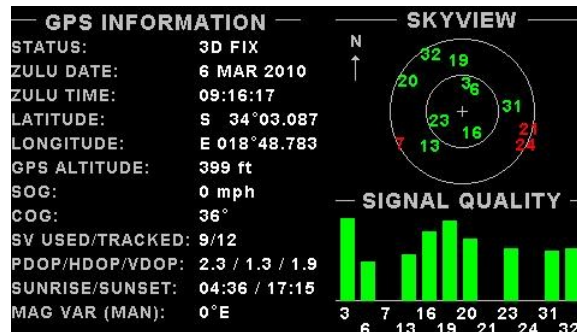

CHECKLIST/INFO DISPLAY

****** SAMPLE CHECKLIST ******
 NORMAL TEXT FILE WITH .ECL EXTENSION
 EACH LINE MUST BE TERMINATED IN CR
 MAXIMUM 60 CHARS PER LINE
 MAXIMUM 30 LINES PER CHECKLIST FILE

3.1 EMS Display

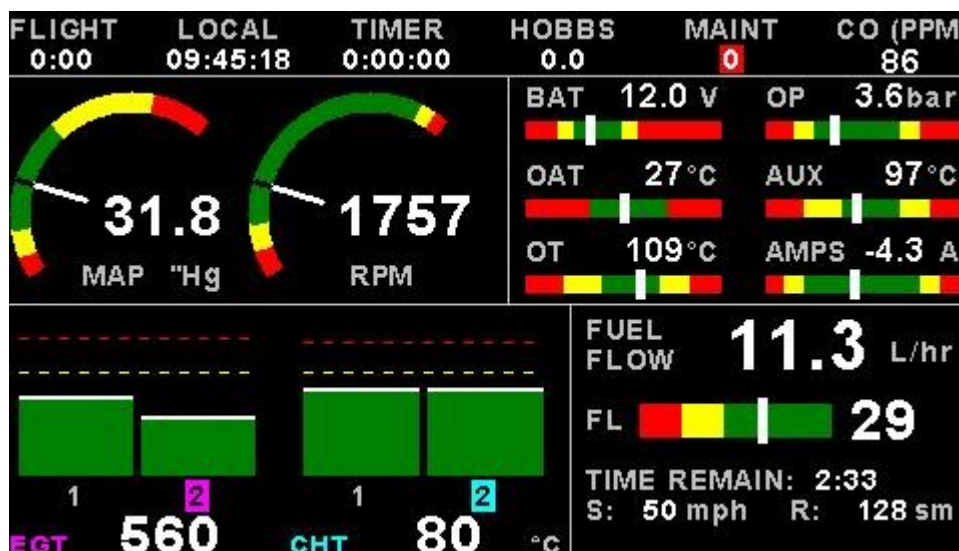

3.1.1 Information bar



FLIGHT:

The flight time is automatically reset to zero when a new flight is started (manual or automatic flight detection). The “:” will flash when a flight is active. The flight timer can be started in the quick select menu (Manual flight mode).

LOCAL:

Local time normally includes an offset from Zulu time. The time offset can be setup in the “TIMERS SETUP” menu.

TIMER:

The Timer can be configured in the quick select menu.

HOBBS:

The XTreme-EMS contains a password protected Hobbs timer. The Hobbs time can be set to the current known engine time in the “TIMERS SETUP” menu. The Hobbs timer will only increment when the RPM is greater then the “HOBBS MINIMUM RPM”.

MAINT (Maintenance Timer):

This timer is set in engine hours and it will count down to zero when the engine RPM is greater then the “HOBBS MINIMUM RPM” value as set in the “TIMERS SETUP”. A good use for this function is to set the hours until your next spark plug change or engine inspection.

The purpose of this function is to assist you in determining remaining hours until maintenance will be required. It is not intended as a replacement for the aircraft's maintenance log. It is therefore important that the aircraft's maintenance log be maintained in the normal manner. You should further use your own discretion in performing maintenance earlier than indicated should any aircraft performance problems arise.

MAINTENANCE TIMER HAS EXPIRED

A maximum of 999 hours can be entered as a maintenance interval. A reminder message will appear on startup when zero hours are remaining. The reminder message will automatically disappear after 10 seconds or if the pilot presses any key. Engine running time for the purpose of the maintenance timer is defined as the run time where the engine RPM is greater than the "HOBBS MINIMUM RPM" value as set in the "TIMERS SETUP".

CO (PPM):

This value is the carbon monoxide PPM value from the CO Monitor Detector (CO Guardian detector required).

3.1.2 RPM / Rotor / MAP display section

The RPM/Rotor/MAP section will maximize the space according to which parameter RPM/Rotor/MAP is enabled. The RPM, Rotor and MAP parameters can be configured in the "EMS SETUP" menu.

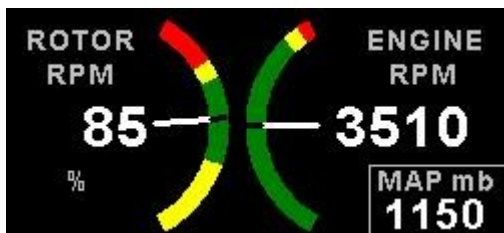

RPM, Rotor and MAP enabled.

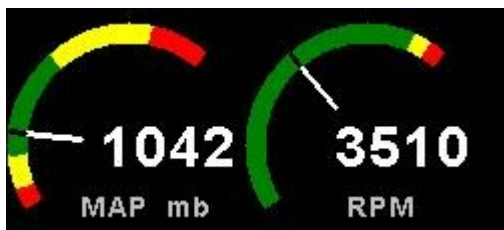

RPM and MAP enabled.



RPM only enabled



MAP only enabled

3.1.3 Volts, OAT, Oil Temperature/Pressure, Current and Auxiliary Analog section



This section displays the supply voltage, OAT, oil temperature, oil pressure, as well as the 2 auxiliary analog channels. The oil temperature/pressure as well as the 2 auxiliary analog channels can be configured in the "EMS SETUP" menu.

3.1.4 Fuel display section

The XTreme-EMS supports dual fuel flow and dual fuel levels. The fuel section will automatically try and maximize the display area according to the fuel parameters selected. The XTreme-EMS has 20 different fuel modes of operation. The fuel parameters can be configured in the "FUEL SETUP" menu.

3.1.4.1 Single fuel flow and calculated tank level (single tank)

- Single fuel flow and fuel level sender (single tank)
- Differential fuel flow and calculated tank level (single tank)
- Differential fuel flow and fuel level sender (single tank)
- Summed fuel flow and calculated tank level (single tank)
- Summed fuel flow and fuel level sender (single tank)



3.1.4.2 Dual fuel flow and calculated tank levels (dual tank)

- Dual fuel flow and dual fuel level senders (dual tank)



3.1.4.3 Single fuel flow and dual fuel level senders (dual tank)

- Single fuel flow, single fuel level sender, single calculated tank
- Differential fuel flow and dual fuel level senders (dual tank)
- Differential flow, single fuel level sender, single calculated tank
- Summed fuel flow and dual fuel level senders (dual tank)
- Summed fuel flow, single fuel level sender, single calculated tank



3.1.4.4 Single/Differential/Summed fuel flow, single fuel level sender, single calculated tank

These modes are nice for multiple fuel tanks whereby one or more tanks are difficult to insert level senders in. Potential problems such as those listed below can easily be diagnosed by doing side by side comparisons between a calculated and physical tank.

- Leaks in the fuel system
- Uneven drain of interconnected tanks
- Malfunction of the level sender
- Malfunction of the flow sender

3.1.4.5 Single fuel flow only indicator

This mode is displayed if either fuel flow 1 or fuel flow 2 is selected and no fuel level senders are selected.

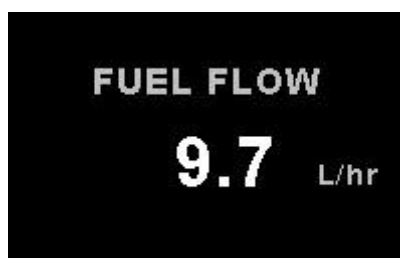

3.1.4.6 Dual fuel flow indicator

This mode is displayed if both fuel flow 1 and fuel flow 2 is selected and the fuel mode is selected for dual flow. Both fuel level senders are disabled.



3.1.4.7 Single tank level indicator

This mode is displayed if either fuel level 1 or fuel level 2 is selected. Both fuel flow senders are disabled.

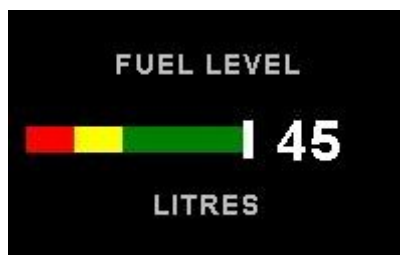

3.1.4.8 Dual tank level indicator

This mode is displayed if both fuel level 1 and fuel level 2 is selected. Both fuel flow senders are disabled.



3.1.4.9 Differential/Summed fuel flow

This mode is displayed if both fuel flow 1 and fuel flow 2 is selected and the fuel mode is selected for either differential or summed.



3.1.4.10 Calculated Fuel Tanks

Calculated fuel tanks will have the text "CALC" in the fuel bar to indicate that the fuel level is calculated from fuel flow and that it is not a physical measure of the fuel tank.



3.1.4.11 Speed, Range and GPS Fix Status

The speed value will change color depending on the source of the information:

White: The XTreme-EMS is using the cruising speed for the range calculation

Magenta: The XTreme-EMS is using the GPS ground speed for the range calculation

Cyan: The XTreme-EMS is using the airtalk airspeed for the range calculation

3.1.5 EGT/CHT display section

The XTreme supports up to 12 thermocouples for EGTs/CHTs. The EGT/CHT section will automatically try and maximize the display area according to the number of EGTs/CHTs selected. The EGT/CHT parameters can be configured in the "EGT SETUP" and "CHT SETUP" menu.

The EGT/CHT number will highlight to the indicated the temperature value if "HIGHEST" is selected. The EGT highlight color is magenta, and the CHT color is cyan.

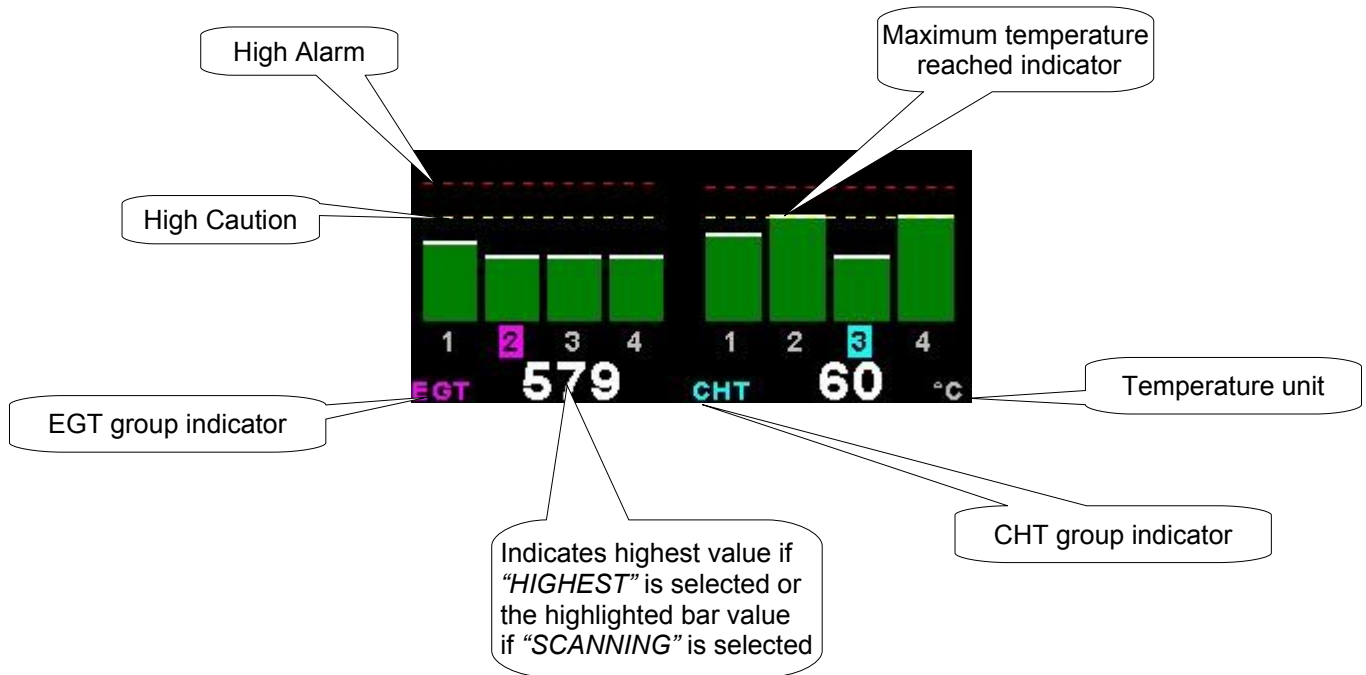

3.2 EMS Quick Select Menu System

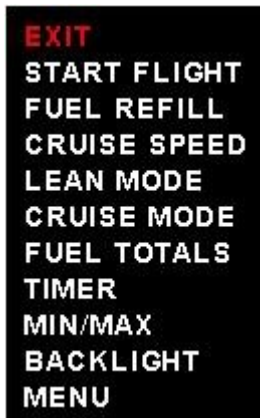

Press the rotary control when the EMS screen is displayed to access the EMS quick select menu.

START FLIGHT:

Select this option to manually start/stop a flight. This menu option is only shown if the XTreme-EMS is setup to select the manual flight option under the “FLIGHT LOG” setup menu. The ‘!’ will flash to indicate that a valid flight is in progress.

FUEL REFILL:

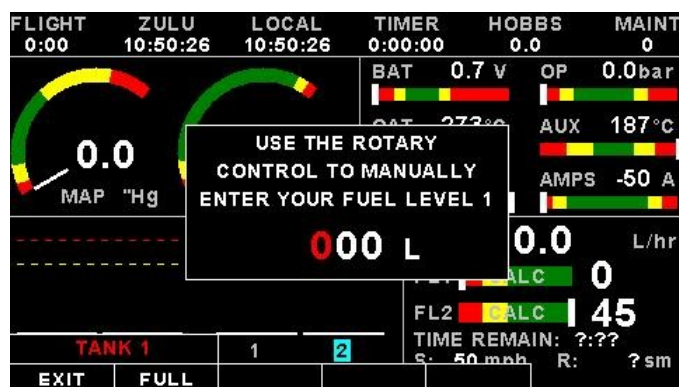

Select this menu option to refill a calculated fuel tank. Press the “FULL” soft key for a quick fill to the full reading in the tank setup menu. Press the “EXIT” soft key when done.

CRUISE SPEED:

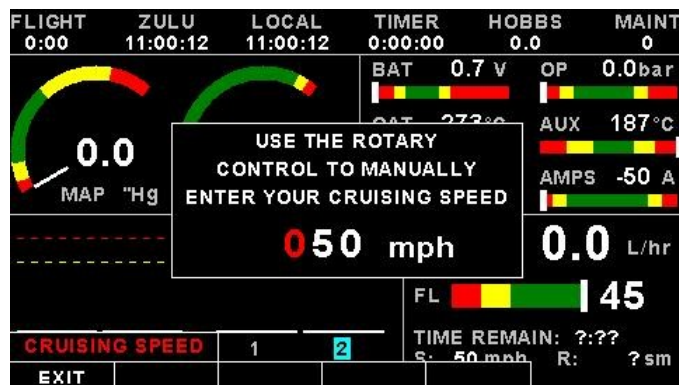

Select this menu option to enter your average cruising speed. If there is no GPS fix or no airtalk airspeed data available then the Xtreme-EMS will use the average cruising speed to calculate fuel range. It is advisable to enter your average cruising speed irrespective if you are using an external GPS receiver or external airtalk airspeed device. If the GPS signal is lost during flight then the Xtreme-EMS automatically defaults to this value.

LEAN MODE:

EGT information is also very useful for fuel mixture control. As the fuel mixture is leaned, so the exhaust gasses get hotter. This rise in temperature is a sign of increased combustion efficiency as the optimum mixture setting is approached. If the leaning progresses past a certain point however, the temperature will begin to drop. This temperature drop is the result of reduced energy output from the diminished fuel flow. The best operating mixture for aircraft engines is in the vicinity of this peak EGT reading. The XTreme-EMS has a special Leaning mode, which easily identifies the peak EGT condition allowing you to adjust your fuel mixture for best performance. Fuel mixture should be adjusted once you have decided on a suitable cruise power setting (typically 70%). Once leaning mode has been enabled, the "LEAN MODE" label is displayed at the bottom left of the EMS display to clearly differentiate it from the normal operating mode. As the fuel mixture is slowly leaned past the point at which the temperature begins to drop (by more than 10°C/15°F), the absolute EGT temperatures will change to show the EGT reading relative to this peak. The sequential order as each cylinder peaks is also shown as numeric text under the cylinder. Leaning mode can be canceled by pressing the soft key to "OFF" or by changing the display screen.

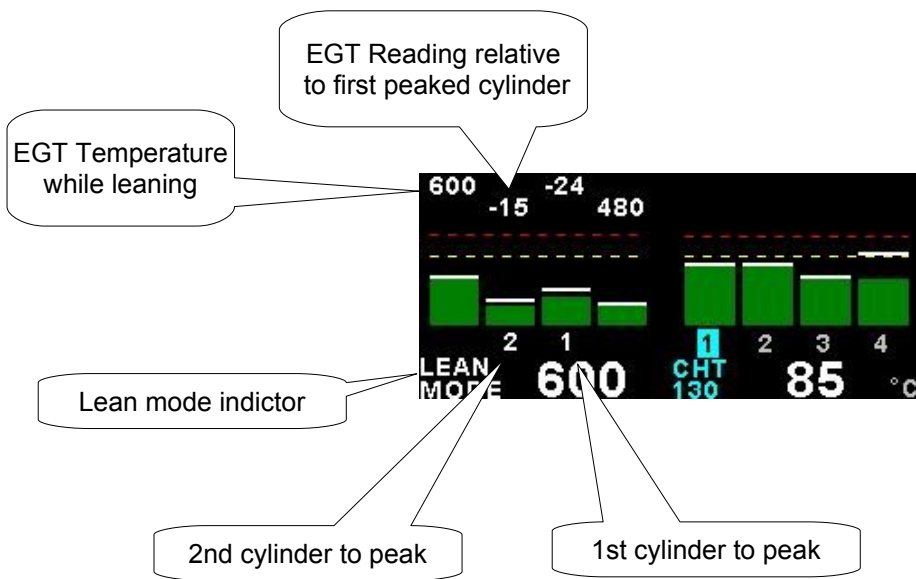

CRUISE MODE:

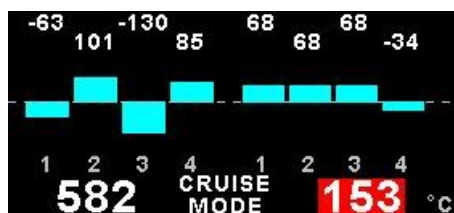

Once cruise mode has been enabled, the "CRUISE MODE" label is displayed at the bottom of the EMS display to clearly differentiate it from the normal operating mode. All EGT and CHT readings are immediately sampled as reference temperatures for the cruise. The display then shows EGT and CHT values relative to this reference temperature. Cruise mode can be canceled by pressing the soft key to "OFF".

FUEL TOTALS:

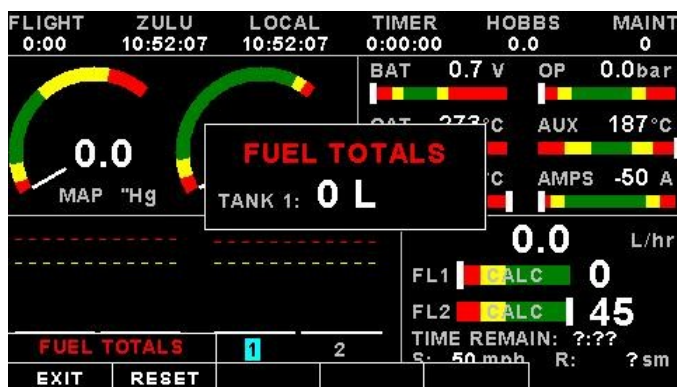

Select this menu option to display the fuel totals. Press the "RESET" soft key to reset the totalisers to zero. Press the "EXIT" soft key when done.

TIMER:

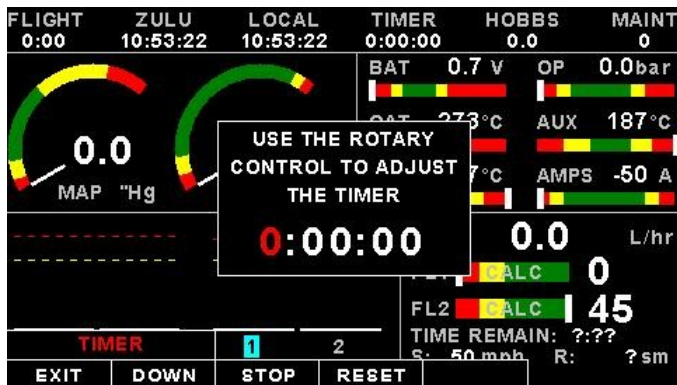

Select this menu option to configure the timer. Use the rotary control to adjust the timers reset value. Press the "UP/DOWN" soft key to select whether the timer must count up or down, the "START/STOP" soft key to start or stop the timer and the "ON/OFF" soft key to enable or disable the timer.

MIN/MAX:

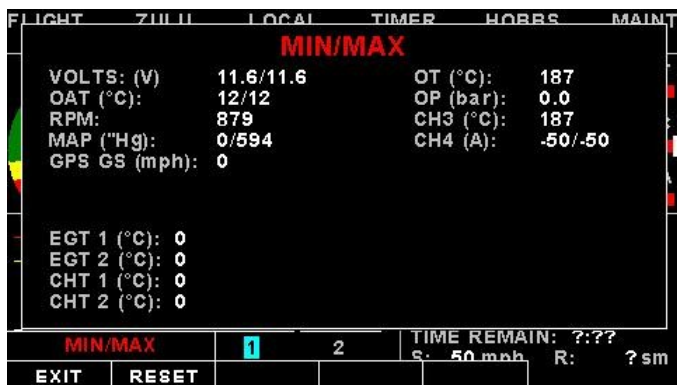

Select this menu option to display the maximum and minimum captured values. Press the "RESET" soft key to reset the min/max values to the current values.

BACKLIGHT:



Select this menu option to adjust the backlight brightness level. This may be desirable during low light flying conditions. Use the rotary control to adjust the brightness level.

MENU:

Select this menu option to enter the main menu system.

3.3 GPS Display (External GPS receiver required)

The GPS page show the GPS information in an easy to read format. Sunrise/sunset times as well as the magnetic variation is shown.

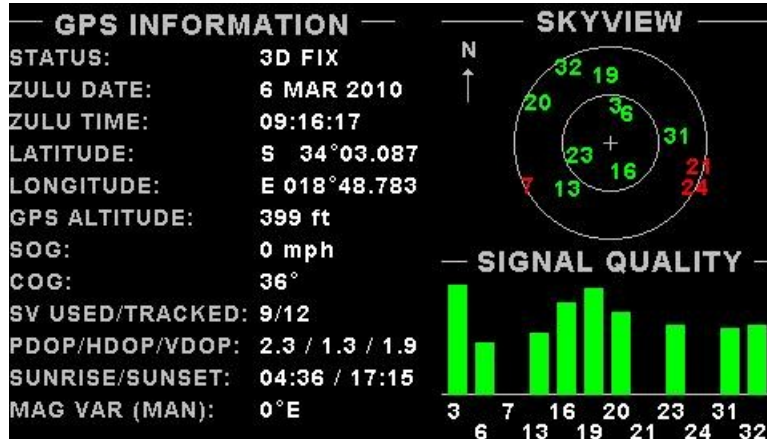

3.4 GPS Quick Select Menu System



Press the rotary control when the GPS screen is shown to access the GPS quick select menu.

BACKLIGHT:



Select this menu option to adjust the backlight brightness level. This may be desirable during low light flying conditions. Use the rotary control to adjust the brightness level.

MENU:

Select this menu option to enter the main menu system.

3.5 Information/Checklist Display

The Information/Checklist page shows checklists and graphic information pages which are loadable from the SD card.

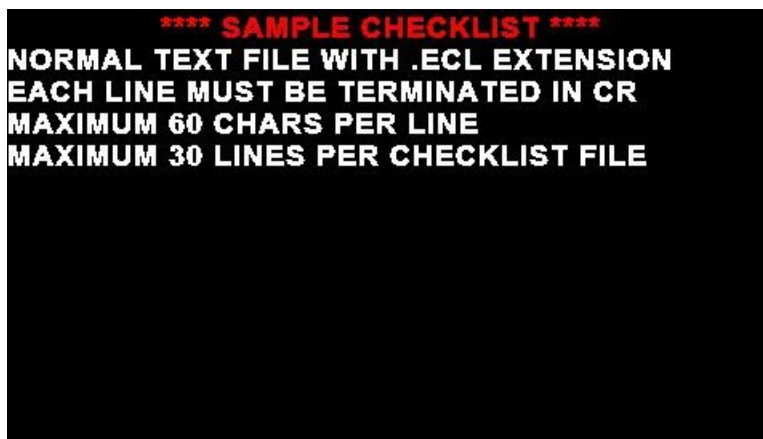

3.5.1 Graphic information pages

The graphic information page allows you to display any type of image on the XTremes high resolution graphics display.

Creating your own graphic information pages

You will need:

- A bitmap picture of your choice (*.BMP, 480x272 pixel resolution)
- The Enigma BMP to MIF converter tool (can be downloaded free of charge from <http://www.mglavionics.co.za> or can be found on the XTreme-EMS distribution SD card).

The Enigma BMP to MIF program is used to convert images in Windows BMP format to Enigma MIF format. You can use this program to make your own startup screen (Splash screen) and graphic information pages. The color depth is limited to Enigmas 256 colors.

Run the Enigma BMP image to MIF format converter program.

Load an image file (and remember the location), select the resolution as width (480) and height (272) and press the process button. The new MIF image will be located in the same directory as the source (.BMP) file. Copy the created file (.MIF extension) to the Infopage directory on the SD card.

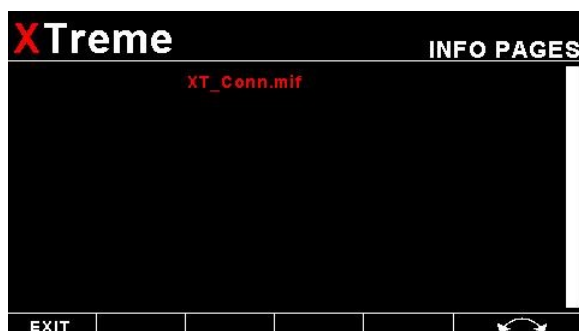

The graphic information file can then be loaded by pressing the rotary control and selecting "INFO PAGES". A window containing all the files with the .MIF extension is shown. Select the desired information page. The number of information pages that can be stored and displayed depends on the size of the SD card.

3.5.2 Checklists

A checklist file is simply a text file created in a word processing program and saved with a .ECL extension. The name of the file does not matter but we suggest calling it something familiar so you can easily identify it. The length of each text line must not be more than 60 characters and must be terminated with an Enter (CR). The line will automatically be truncated at the end of the right hand side of the screen. Each checklist file must not be more than 30 lines.



Copy the created file (.ECL extension) to the checklst directory on the SD card when you are complete. The checklist file can be loaded by pressing the rotary control and selecting "CHECKLISTS". A window containing all the files with the .ECL extension will be shown. Select the checklist you require. The number of checklists that can be stored and displayed depends on the size of the SD card.

3.6 Information/Checklist Quick Select Menu System



Press the rotary control when the Info/Checklist screen is shown to access the Info/checklist quick select menu.

INFO PAGES:

This menu option selects a graphic information page to display. A window will open displaying all the files with the .MIF extension in the Infopage directory on the SD card. Press the rotary control over the file you wish to load as a graphic information page.

CHECKLISTS:

This menu option selects a checklist to display. A window will open displaying all the files with the .XCL extension in the Checklst directory on the SD card. Press the rotary control over the file you wish to load as a checklist.

BACKLIGHT:



Select this menu option to adjust the backlight brightness level. This may be desirable during low light flying conditions. Use the rotary control to adjust the brightness level.

MENU:

Select this menu option to enter the main menu system.

4 Main Menu System

EXIT
 START FLIGHT
 CRUISE SPEED
 LEAN MODE
 CRUISE MODE
 FUEL TOTALS
 TIMER
 MIN/MAX
 BACKLIGHT
MENU

To access the main menu system, press the rotary control knob, scroll down to the "MENU" option and press the rotary control knob again. Use the rotary control to navigate through the menu system.

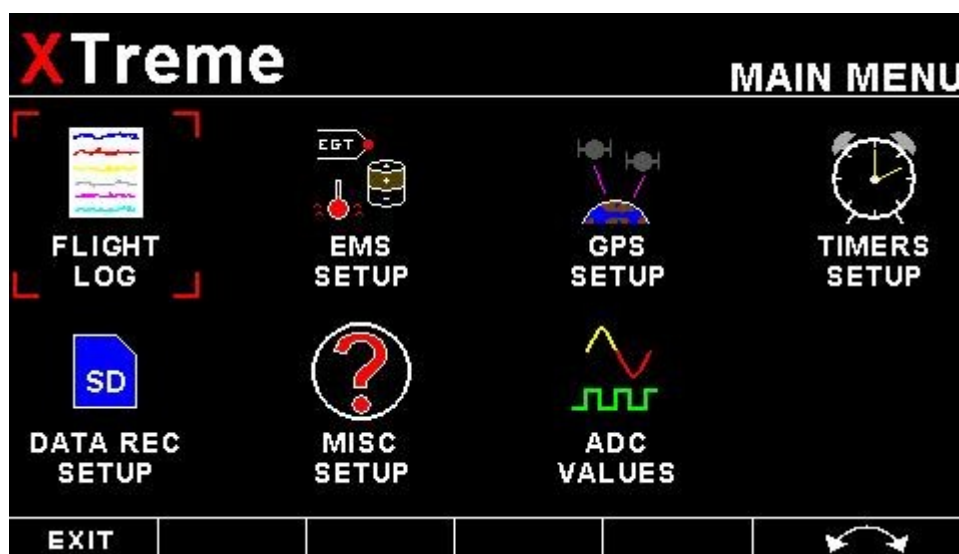

4.1 Menu Sub-Bar



Use the menu sub-bar for quick menu navigation. Select the soft key directly under the text to activate that function.

4.2 Flight Log



NOTE: The Flight log is stored in RAM until a valid flight has been completed. If the power is turned off to the XTreme-EMS before the flight has ended then the flight information will be lost.

EXPORT FLIGHT LOG TO SD CARD (.CSV FILE):

Use this function to export the current flight logs stored in the XTreme-EMS to a SD card. The exported filename is called XTFLIGHT.CSV. The exported flight log is exported in a CSV (Comma Separated Variable) file format and can be imported into programs such as Microsoft Excel and Open Office.

VIEW FLIGHT LOG:

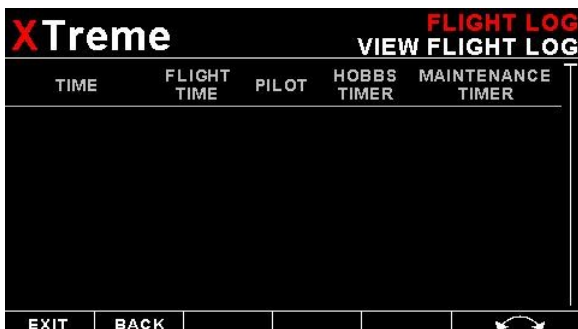

This allows the pilot to view the last 1000 recorded flights.

ERASE FLIGHT LOG:

Use this function to erase the current flight log stored in the XTreme-EMS.

PILOT NUMBER:

Select a pilot number under which the next flights will be logged. Every flight entry in the flight log has a pilot number associated to it.

FLIGHT DETECT:

Select if you want the flight log to automatically "AUTOMATIC" start or if you want to manually "MANUAL" start and stop it.

The XTreme uses the following algorithm to determine if a flight is in progress (*"AUTOMATIC" mode*): If the ground speed is greater than the preset *"FLIGHT DETECT MIN GROUND SPEED"* value or the RPM is greater than the preset *"FLIGHT DETECT MINIMUM RPM"* value for a duration of 60 seconds or more, a flight is started with a logbook entry. The flight ends if ground speed or RPM falls below the preset value for 30 seconds.

The above algorithm ensures that touch-and-goes will not result in the end of a flight and a logbook entry.

FLIGHT DETECT MINIMUM RPM: (Automatic mode only)

Enter the minimum RPM threshold that will start a new flight log entry.

FLIGHT DETECT MINIMUM GROUND SPEED: (Automatic mode only, External GPS Required)

Enter the minimum ground speed threshold that will start a new flight log entry.

4.3 EMS Setup

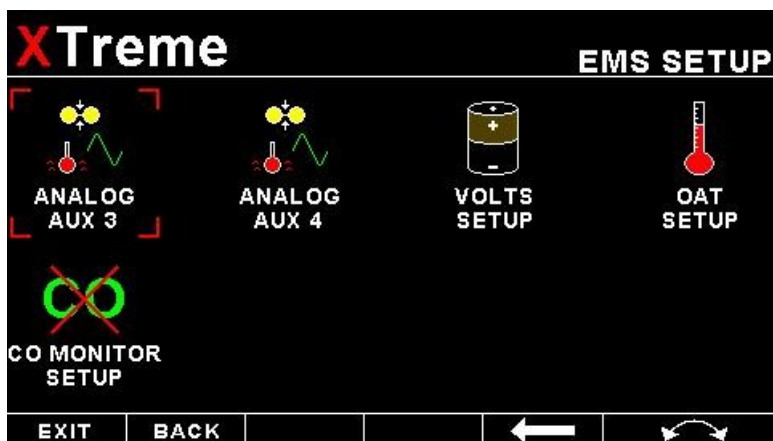
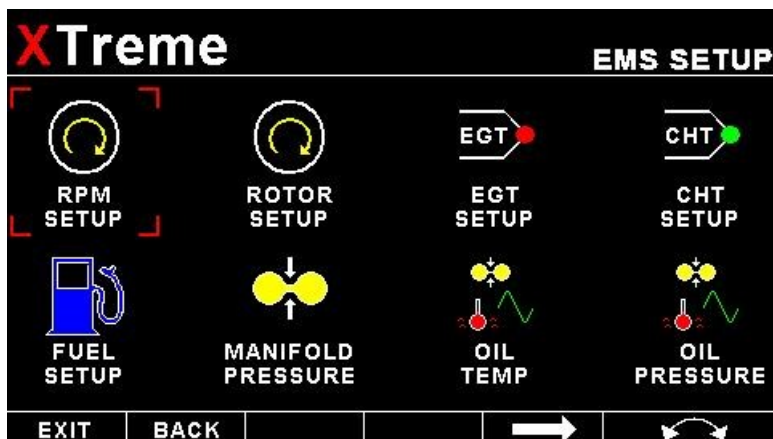

4.3.1 RPM Setup

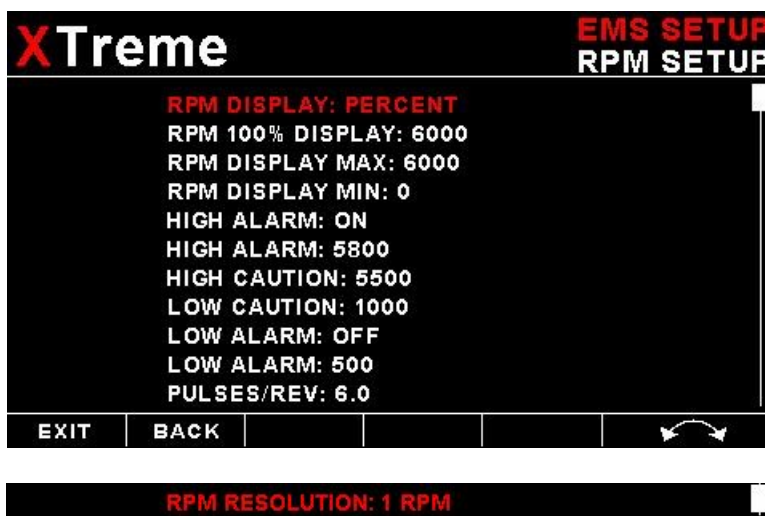

RPM DISPLAY:

Select if you want the RPM to be displayed in “RPM” or “PERCENT”. If you do not want any RPM information then set this parameter to “OFF”. If the rotor RPM is set to “RPM” or “PERCENT” then the engine RPM display will automatically be enabled.

RPM 100% DISPLAY:

Select the maximum value that you want the RPM to correlate to 100%.

RPM DISPLAY MAX:

Select the maximum RPM that you want the RPM dial to show. This can give you increased display resolution.

RPM DISPLAY MIN:

Select the minimum RPM that you want the RPM dial to show. This can give you increased display resolution.

HIGH ALARM:

This enables or disables the RPM high alarm.

HIGH ALARM:

Enter the RPM threshold for when the high alarm must be activated. Any RPM value above this value will activate the alarm.

HIGH CAUTION:

Enter the RPM value for the high caution. This is the lower value of the upper yellow band.

LOW CAUTION:

Enter the RPM value for the low caution. This is the upper value of the lower yellow band.

LOW ALARM:

This enables or disables the RPM low alarm.

LOW ALARM:

Enter the RPM threshold for when the low alarm must be activated. Any RPM value below this value will activate the alarm.

PULSES/REV:

Enter the number of pulses per RPM. For engines with an uneven number of cylinders like three cylinder four stroke engines you can enter values containing fractions (usually 1.5 in this example). Most four stroke engines would generate one pulse for every two revolutions per cylinder. A four cylinder automotive four stroke engine would thus generate 2 pulses per revolution. A typical Rotax DCDI two stroke engine would generate 6 pulses per revolution. The well known Rotax 912/914 engine generates one pulse per revolution.

RPM RESOLUTION:

Select the step size between successive RPM values eg. if the RPM value is 4003 RPM and the "RPM RESOLUTION" is 5 then the actual value shown is 4005 RPM.

4.3.2 Rotor Setup

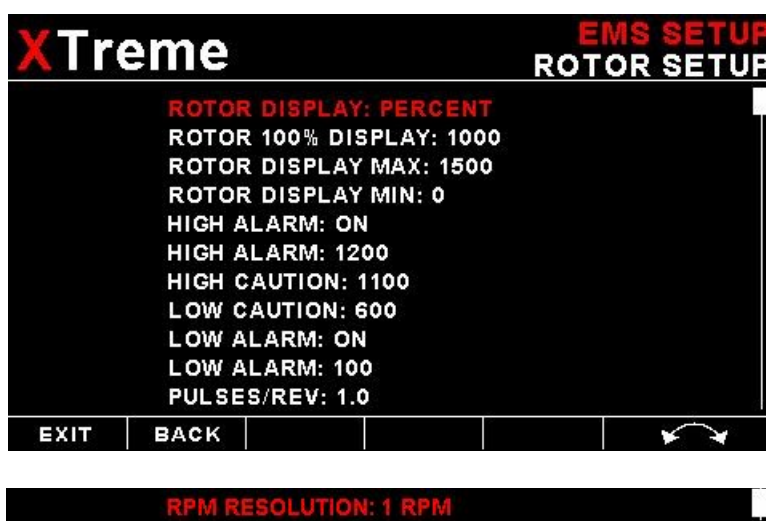

ROTOR DISPLAY:

Select if you want the rotor RPM to be displayed in "RPM" or "PERCENT" .If you do not want any rotor RPM information then set this parameter to off. If the rotor RPM is set to "RPM" or "PERCENT" then the engine RPM display will automatically be enabled.

ROTOR 100% DISPLAY:

Select the maximum value that you want the rotor RPM to correlate to 100%.

HIGH ALARM:

This enables or disables the Rotor RPM high alarm.

HIGH ALARM:

Enter the Rotor RPM threshold for when the high alarm must be activated. Any Rotor RPM value above this value will activate the alarm.

HIGH CAUTION:

Enter the Rotor RPM value for the high caution. This is the lower value of the upper yellow band.

LOW CAUTION:

Enter the Rotor RPM value for the low caution. This is the upper value of the lower yellow band.

LOW ALARM:

This enables or disables the Rotor low alarm.

LOW ALARM:

Enter the Rotor RPM threshold for when the low alarm must be activated. Any Rotor RPM value below this value will activate the alarm.

PULSES/REV:

Enter the number of pulses per rotor RPM.

ROTOR RESOLUTION:

Select the step size between successive Rotor RPM values eg. if the Rotor RPM value is 403 RPM and the "*ROTOR RESOLUTION*" is 5 then the actual value shown is 405 RPM.

4.3.3 EGT/CHT Setup

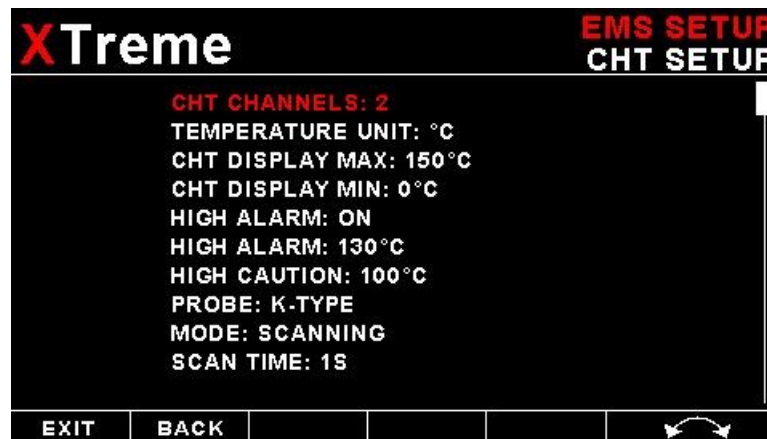
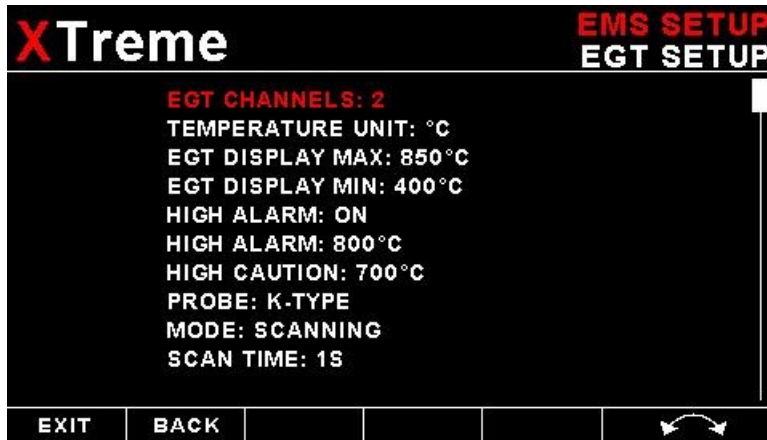

EGT/CHT CHANNELS:

Select the number of EGT or CHT channels you want to use. Choices are from 1 to 12. The temperature display will configure itself to make best possible use of the available display size. Please note that the minimum number of EGT & CHT channels that can be displayed is 1 and the maximum number of EGT and CHT channels that can be displayed is 12.

EGT/CHT DISPLAY MAX:

Select the maximum temperature that you want the EGT/CHT bargraph to show. This can give you increased display resolution.

EGT/CHT DISPLAY MIN:

Select the minimum temperature that you want the EGT/CHT bargraph to show. This can give you increased display resolution.

HIGH ALARM:

This enables or disables the EGT/CHT high alarm.

HIGH ALARM:

Enter the temperature threshold for when the high alarm must be activated. Any temperature above this value will activate the alarm.

HIGH CAUTION:

Enter the temperature value for the high caution.

PROBE:

Select if you are using a K-type, J-type or E-type thermocouple probe for the EGT/CHT group. All probes supplied by MGL Avionics are K-Type. J-types are sometimes used with American made CHT probes. All EGT probes are K-type. E-type probes are seldom used.

TEMPERATURE UNIT:

Select whether you want the EGT/CHT temperature to be displayed in degrees Celsius (°C) or degrees Fahrenheit (°F).

MODE:

A selection between "HIGHEST" or "SCANNING" can be selected. If "HIGHEST" is selected then the current highest thermocouple temperature is displayed. If "SCANNING" is selected then the unit will cycle through each thermocouple at the time specified in "SCAN TIME".

SCAN TIME:

Specify the time that each of the channels must be displayed for. This menu option is only shown if "SCANNING" is selected for the display mode.

4.3.3.1 Special Rotax 912/914 probe mode

In this mode the RDAC AUX 3 and AUX 4 analog input channels become the Rotax CHT channel 1 and CHT channel 2 respectively. All CHT setups must still be done under the "CHT SETUP" menu. The sender selection for the "AUX 3" and "AUX 4" must be set for "OFF". A probe type of "NTC" must be selected for the probe setting in the "CHT SETUP" menu.

The reason for using the NTC inputs is that the sensors Rotax use are standard NTC temperature probes and not of a thermocouple type.

4.3.4 Fuel Setup

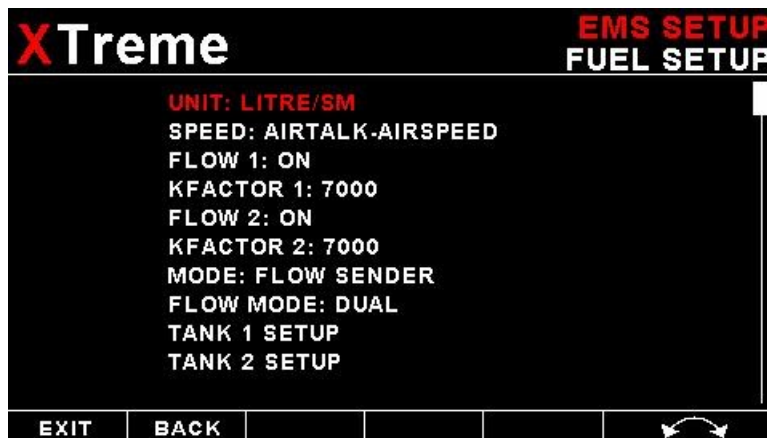

UNIT:

Select your desired units for distance and fuel quantity. The following options are available:

- L/sm: Liters and statute miles
- G/sm: U.S. Gallons and statute miles
- L/nm: Liters and nautical miles
- G/nm: U.S. Gallons and nautical miles
- L/km: Liters and kilometer
- G/km: U.S. Gallons and kilometers

SPEED:

Select which speed will be used for fuel range/endurance based calculations. You can select between "AIRTALK-AIRSPEED" which can be transmitted from an external airspeed indicator such as the MGL Avionics ASI-1/3 or "GPS-GROUND SPEED". If a 2D or 3D GPS is not obtained and "GPS-GROUND SPEED" is selected then the XTreme-EMS will default to use the cruising speed for the fuel range/endurance calculations.

FLOW 1/2:

This enables or disables the Flow 1/2 display on the EFIS and MFD displays.

KFACTOR 1/2:

The K-Factor is the number of pulses generated by the fuel flow sender for one liter of fuel. The dual range fuel flow sender supplied by MGL Avionics has a K-Factor of 7000 in the low flow mode (jet installed) and 1330 for the high flow mode (no jet installed). The Flowscan 201A-6 has a K-Factor of 8454. You can use the K-Factor to calibrate your fuel flow sender. See the RDAC manual for more details on how to calibrate and install the fuel flow sender.

MODE:

Select if you want to measure fuel flow using a fuel flow sender or by using fuel injectors.

FLOW MODE:

If both fuel flow senders are selected then select if they are operating on individual fuel tanks (dual) or if they are operating in a supply/return type fuel system (differential).

TANK 1/2 SETUP:

Select this menu item to setup the fuel level for fuel tank 1/2. See below for more details.

Fuel level setup. (Only tank 1 setup is shown, follow the same steps for tank 2 setup)

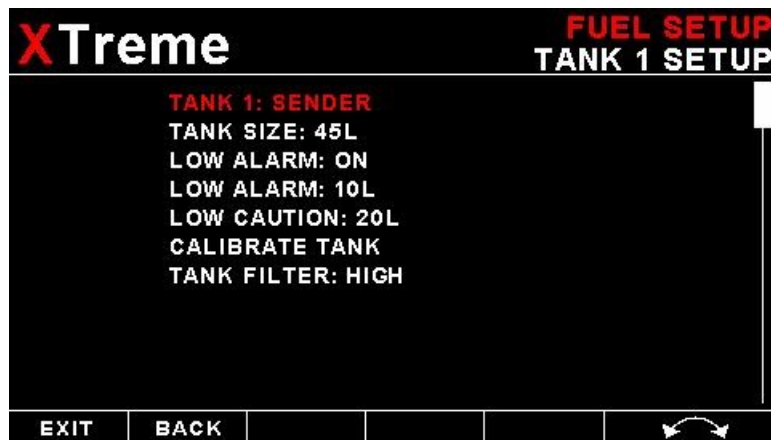

TANK 1/2:

Select if the fuel tank has a physical fuel level sender connected to it or if the Xtreme must use a calculation based virtual fuel tank. If you do not want any fuel level information then set this parameter to off.

TANK SIZE:

Enter the size of the fuel tank in your system. It is recommended to choose a size that is slightly less than the actual size so you can compensate for sender inaccuracies and give you a measure of reserve fuel.

LOW ALARM:

This enables or disables the fuel level low alarm.

LOW ALARM:

Enter your desired minimum fuel value that you would like to trigger the fuel low alarm.

LOW CAUTION:

Enter the fuel level value for the low fuel caution.

CALIBRATE TANK:

The fuel level sender needs to be calibrated before it can be used with this system. The calibration allows the system to learn the shape of your tank as well as any errors your fuel level sender or installation has.

Regardless of your use of a fuel flow sender, you can install a fuel level sender into your fuel tank. These level senders are inexpensive and are available as after market replacement fittings from a car spares outlet. We recommend the senders available from VDO.

Be aware that some makes of cheap level senders can prove troublesome, as the lever arms tend to be sticky. This prevents the floats from floating on the surface of the fuel at all times. As a consequence, this will lead to incorrect fuel level indication.

Adjusting calibration points automatically

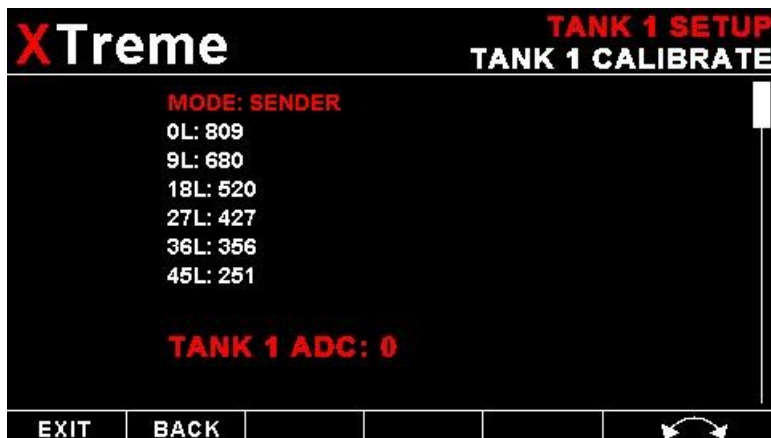

Select "SENDER" for the "MODE" menu item. Once you have installed a fuel level sender into your tank, make sure the float can travel all the way from empty to full position without hindrance of any kind. The calibration procedure should be carried out with your aircraft in flight attitude. This means you need to lift the tail if you have a tail-dragger or lift the nose wheel if you have a weightshift trike.

Calibration procedure

- Start the calibration procedure with an empty tank.
- Add five liters of fuel (our reserve quantity) using a suitable measure. Make sure the measure is suitably accurate. This is now the "level sender reading at 0 Lt" position. Move the highlight to this position and wait until the sender reading has stabilized (You will see the sender reading at the top line). This could take up to a minute so have patience.

ENSURE THAT THE FLOAT IS NOT SUBMERGED AND IS FLOATING ON TOP OF THE FUEL LEVEL.

Should this number not react to changes of your level sender position, then you have a problem. Please check your wiring according to the installation section of this manual. You should expect the number to change in the region of at least 20 to 60 counts per calibration position. If the number does not change with fuel level or only changes a very small amount – check your installation. Something is not right!

- If you see the number changing then everything is well. Once it has stabilized and the highlight is on the 0 L position, press the rotary control to transfer the reading from the sender to the calibration point.
- Now you are ready for the next step. Add the required amount of fuel to get to the next level (In our case 9 Lt – this is 20% tank capacity). Once done, wait for the reading to stabilize and press the rotary control again after you have moved the highlight to the "9 L" position.
- Proceed in a similar manner until you have reached the last calibration position at 100% tank capacity.

You are done!

To finish your calibration, exit the calibration function by moving the highlight over the "-- PREVIOUS MENU --" menu item and press the rotary control.

The instrument uses the 6 calibration points to work out a correction curve that takes into account the tolerances of your fuel level sender and the shape of your fuel tank. This results in an incredibly accurate and usable fuel level display that far exceeds that available from ordinary dial type gauges.

Adjusting calibration points manually

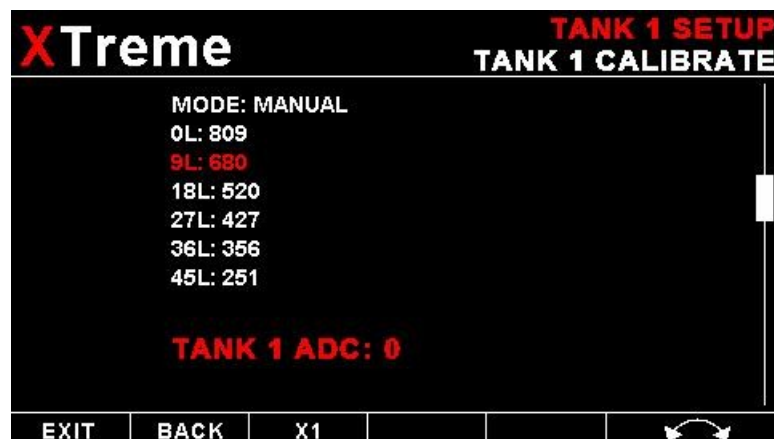

You may want to set individual calibration points manually. For example you may find that your fuel level is over reading at a specific fuel level. Correcting the tank level reading for this area can be simply done by adjusting the calibration point. You can do this by moving the float level with your hands to the desired position and then performing the calibration as outlined above, or you can use the manual option.

Select "MANUAL" for the "MODE" menu item. Then highlight the point you want to change manually and press the rotary control. Use the rotary control to adjust the value. Press the rotary control when done.

Note: The calibration positions may be edited by using the rotary control. This allows you, in theory, to copy calibration settings from one instrument to another. We however recommend that you do go through the calibration procedure even if the two aircraft are identical in all respects. Tolerances do exist and the calibration cancels these out. Accurate fuel level displays are a vital safety factor for an aircraft and a very useful feature for peace of mind during cross county flights.

Notes on Slope error

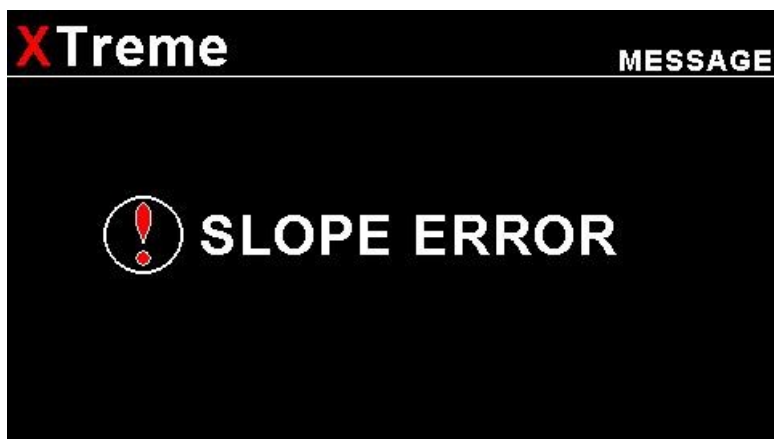

Sender value is a value determined by the XTreme. It is used to calculate fuel level, fuel endurance estimate and current range estimate. The fuel tank setup sender value can either increase in value as fuel is added or decrease in value if fuel is added. This is dependent on the type of fuel level sender used. However should the second reading be larger than the first reading all readings will have to be larger than the previous readings. Likewise should the second reading be smaller than the first reading all readings will have to be smaller than the previous reading.

If this is not the case the wording "SLOPE ERROR" will be displayed. This could happen when fuel was removed instead of added between steps, no fuel was added between steps or when the fuel level sender was moved in the wrong direction e.g. moving the fuel level sender manually when it is not inserted in to the fuel tank. Determine the cause of the error if you should get a slope error message. If you do not know the cause of your error it is best to start from scratch. It should be remembered that accuracy in the fuel tank calibration is extremely important to enable your XTreme to display the correct data.

TANK FILTER:

Select the damping factor for the fuel level. A selection of "NONE", "LOW", "MED" or "HIGH" can be made.

4.3.5 Manifold Setup

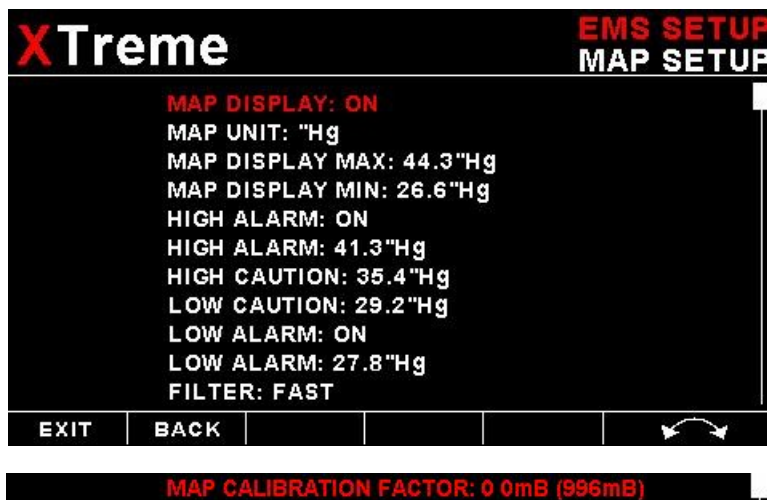

MAP DISPLAY:

This enables or disables the manifold pressure display on the EMS displays screens

MAP UNIT:

Select if you want the manifold pressure displayed in mB (millibars) or "Hg (inches of mercury).

MAP DISPLAY MAX:

Select the maximum pressure that you want the manifold bargraph in the EMS displays to show. This can give you increased display resolution.

MAP DISPLAY MIN:

Select the minimum pressure that you want the manifold bargraph in the EMS display to show. This can give you increased display resolution.

HIGH ALARM:

This enables or disables the manifold pressure high alarm.

HIGH ALARM:

Enter the pressure threshold for when the high alarm must be activated. Any pressure above this value will activate the alarm.

HIGH CAUTION:

Enter the pressure value for the high caution. This is the lower value of the upper yellow band.

LOW CAUTION:

Enter the pressure value for the low caution. This is the upper value of the lower yellow band.

LOW ALARM:

This enables or disables the manifold pressure low alarm.

LOW ALARM:

Enter the pressure threshold for when the low alarm must be activated. Any pressure below this value will activate the alarm.

FILTER:

This function can be used to select the signal filter time constant. Selections are "NONE", "FAST" or "SLOW". This selection influences the rate at which your manifold pressure can change its reading.

MAP CALIBRATION FACTOR:

The sender in the RDAC is shipped uncalibrated. To calibrate the manifold pressure, compare and adjust the calibration factor until the manifold reading is the same as the pressure value in brackets. The pressure value in brackets is the barometer reading built into the Xtreme. The manifold pressure can only be calibrated in mB.

4.3.6 Oil Temperature Setup

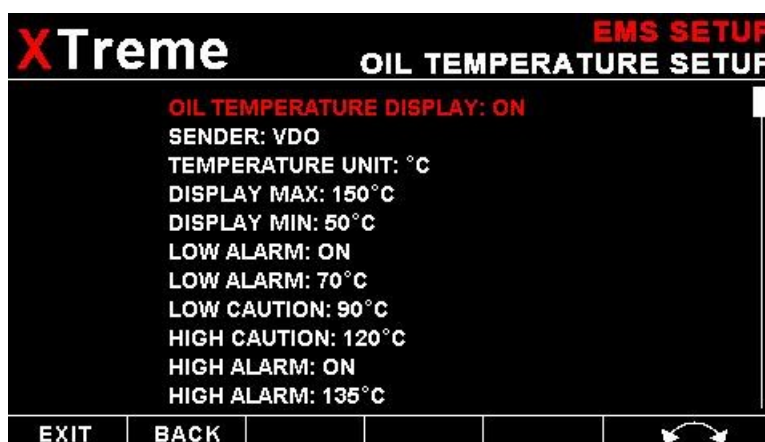

OIL TEMPERATURE DISPLAY:

This enables or disables the oil temperature display on the EMS displays screens

SENDER:

Select what type of sender you are using. Select “VDO” for a VDO resistive sender, “WESTACH” for Westach thermistor type senders, “MGL” for a MGL NTC resistive temperature sender, “LM335” for a MGL precision temperature sender or “USER” for a custom sender. The XTreme has a built in linearization curve for a standard 50°C to 150°C VDO resistive sender, Westach senders and the MGL NTC resistive sender.

If the sender type is set to “USER”

CALIBRATE SENDER:

If the sender type is set to “USER”, then use this menu option to calibrate your temperature sender. See section 4.4.9 for more information.

If the sender type is set to “LM335”

LM335:

If the sender type is set to LM335, then use this menu option to calibrate your LM335 precision temperature sender. If recalibration is required then adjust the value using the rotary control until the temperature matches the reference ambient temperature. Please note that the LM335 can only be calibrated in degrees Celsius irrespective if the XTreme is setup to display temperature in Fahrenheit.

Menu options for all sender types

TEMPERATURE UNIT:

Select whether you want the temperature to be displayed in degrees Celsius (°C) or in degrees Fahrenheit (°F).

DISPLAY MAX:

Select the maximum temperature that you want the oil temperature bargraph to show. This can give you increased display resolution.

DISPLAY MIN:

Select the minimum temperature that you want the oil temperature bargraph to show. This can give you increased display resolution.

LOW ALARM:

This enables or disables the oil temperature low alarm.

LOW ALARM:

Enter the temperature threshold for when the low alarm must be activated. Any temperature below this value will activate the alarm.

LOW CAUTION:

Enter the temperature value for the low caution. This is the upper value of the lower yellow band.

HIGH CAUTION:

Enter the temperature value for the high caution. This is the lower value of the upper yellow band.

HIGH ALARM:

This enables or disables the temperature high alarm.

HIGH ALARM:

Enter the temperature threshold for when the high alarm must be activated. Any temperature above this value will activate the alarm.

4.3.7 Oil Pressure Setup

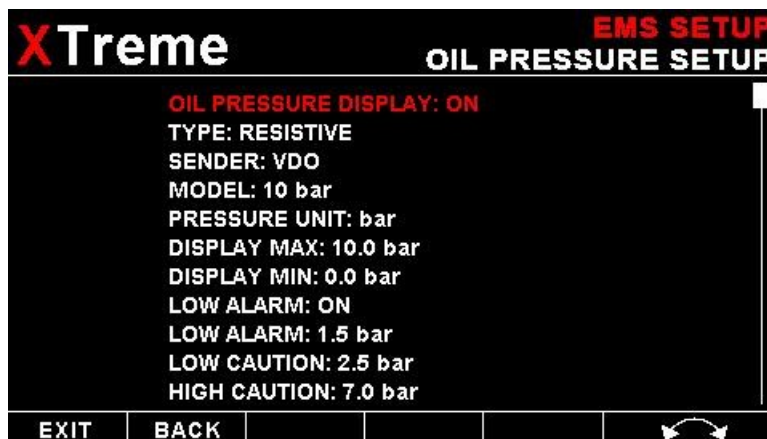

OIL PRESSURE DISPLAY:

This enables or disables the oil pressure display on the EMS displays screens

TYPE:

Select if you are using a resistive, 4-20mA or 0-5V output pressure sender.

If the “RESISTIVE” pressure sender is selected

SENDER:

Select what type of resistive pressure sender you are using. Select “VDO” for VDO / resistive senders, “USER” for a custom sender.

MODEL:

Select which VDO pressure sender you are using. A selection between a VDO 2, 5 or 10 Bar can be selected.

If the “0-5V” pressure sender is selected

SENDER:

Select the type of 0-5V sender used. Select “UMA” for UMA senders or “USER” for a custom 0-5V sender.

MODEL:

For UMA senders select the UMA model number.

If the “4-20mA” pressure sender is selected

SENDER:

Select the type of 4-20mA sender used. Select “ROTAX” for Rotax 912/914 4-20mA sender or “USER” for a custom 4-20mA sender.

PRESSURE @ 4mA:

Enter the pressure specified at 4mA output.

PRESSURE @ 20mA:

Enter the pressure specified at 20mA output.

If the “USER” pressure sender is selected**CALIBRATE SENDER:**

If the sender type is set to “USER”, then use this menu option to calibrate your pressure sender. See section 4.4.9 for more information.

Menu options for all sender types**PRESSURE UNIT:**

Select whether you want to display the pressure in Bar, PSI or PSI(0.1). The PSI(0.1) is for low range pressure senders e.g. UMA 7PSI.

DISPLAY MAX:

Select the maximum pressure that you want the oil pressure bargraph to show. This can give you increased display resolution.

DISPLAY MIN:

Select the minimum pressure that you want the oil pressure bargraph to . This can give you increased display resolution.

LOW ALARM:

This enables or disables the pressure low alarm.

LOW ALARM:

Enter the pressure threshold for when the low alarm must be activated. Any pressure below this value will activate the alarm.

LOW CAUTION:

Enter the pressure value for the low caution. This is the upper value of the lower yellow band.

HIGH CAUTION:

Enter the pressure value for the high caution. This is the lower value of the upper yellow band.

HIGH ALARM:

This enables or disables the manifold pressure high alarm.

HIGH ALARM:

Enter the pressure threshold for when the high alarm must be activated. Any pressure above this value will activate the alarm.

4.3.8 Auxiliary analog 3/4 Setup



The analog AUX3/4 channel on the RDAC is a general purpose channel that can be used for pressure as well as for temperature senders.

FUNCTION:

Select the function for the analog channel. Options are “PRESSURE”, “TEMPERATURE”, “CURRENT” or “OFF”.

If the “PRESSURE” function is selected:

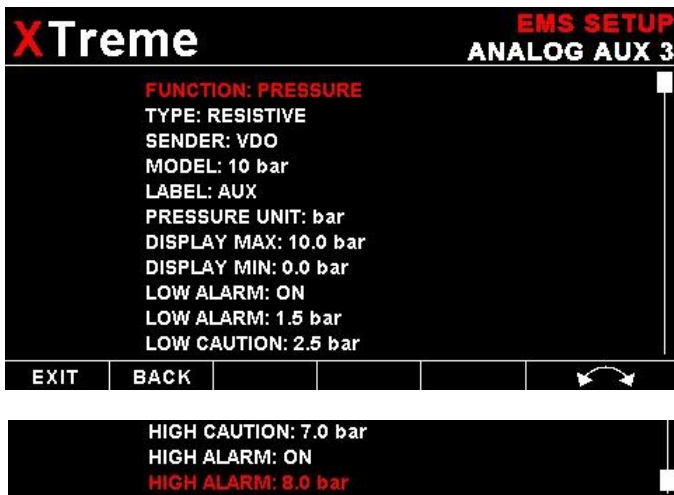

TYPE:

Select if you are using a resistive, 4-20mA or 0-5V output pressure sender.

If the “RESISTIVE” pressure sender is selected

SENDER:

Select what type of resistive pressure sender you are using. Select “VDO” for VDO / resistive senders, “USER” for a custom sender.

MODEL:

Select which VDO pressure sender you are using. A selection between a VDO 2, 5 or 10 Bar can be selected.

If the “0-5V” pressure sender is selected

SENDER:

Select the type of 0-5V sender used. Select “UMA” for UMA senders of “USER” for a custom 0-5V sender.

MODEL:

For UMA senders select the UMA model number.

If the “0-20mA” pressure sender is selected**SENDER:**

Select the type of 4-20mA sender used. Select “ROTAX” for Rotax 912/914 4-20mA sender or “USER” for a custom 4-20mA sender.

PRESSURE @ 4mA:

Enter the pressure specified at 4mA output.

PRESSURE @ 20mA:

Enter the pressure specified at 20mA output.

If the “USER” pressure sender is selected**SENDER:**

Select the type of 4-20mA sender used. Select “ROTAX” for Rotax 912/914 4-20mA sender or “USER” for a custom 4-20mA sender.

CALIBRATE SENDER:

If the sender type is set to “USER”, then use this menu option to calibrate your pressure sender. See section 4.4.9 for more information.

Menu options for all sender types**LABEL:**

Choose one of a selection of labels to suit your pressure input so you can identify it easily.

PRESSURE UNIT:

Select whether you want to display the pressure in Bar, PSI or PSI(0.1). The PSI(0.1) is for low range pressure senders e.g. UMA 7PSI.

DISPLAY MAX:

Select the maximum pressure that you want the bargraph to show. This can give you increased display resolution.

DISPLAY MIN:

Select the minimum pressure that you want the bargraph to show. This can give you increased display resolution.

LOW ALARM:

This enables or disables the pressure low alarm.

LOW ALARM:

Enter the pressure threshold for when the low alarm must be activated. Any pressure below this value will activate the alarm.

LOW CAUTION:

Enter the pressure value for the low caution. This is the upper value of the lower yellow band.

HIGH CAUTION:

Enter the pressure value for the high caution. This is the lower value of the upper yellow band.

HIGH ALARM:

This enables or disables the manifold pressure high alarm.

HIGH ALARM:

Enter the pressure threshold for when the high alarm must be activated. Any pressure above this value will activate the alarm.

If the “TEMPERATURE” function is selected:

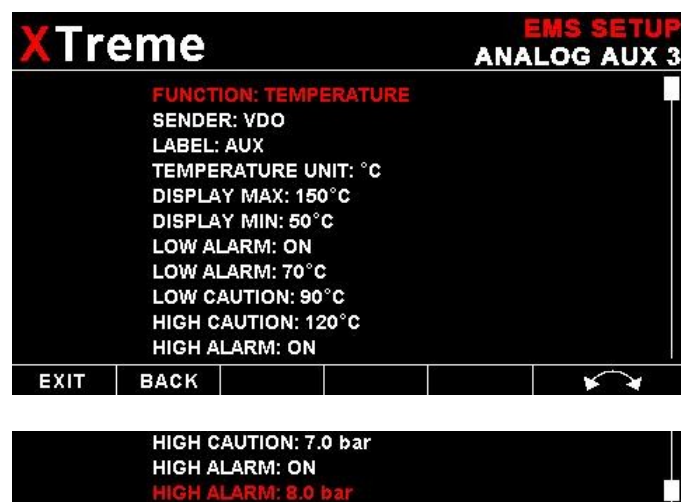

SENDER:

Select what type of sender you are using. Select “VDO” for a VDO resistive sender, “WESTACH” for Westach thermistor type senders, “MGL” for a MGL NTC resistive temperature sender, “LM335” for a MGL precision temperature sender or “USER” for a custom sender. The XTreme has a built in linearization curve for a standard 50°C to 150°C VDO resistive sender, Westach senders and the MGL NTC resistive sender.

If the sender type is set to “USER”

CALIBRATE SENDER:

If the sender type is set to “USER”, then use this menu option to calibrate your pressure sender. See section 4.4.9 for more information.

If the sender type is set to “LM335”

LM335:

If the sender type is set to LM335, then use this menu option to calibrate your LM335 precision temperature sender. If recalibration is required then adjust the value using the rotary control until the temperature matches the reference ambient temperature. Please note that the LM335 can only be calibrated in degrees Celsius irrespective if the XTreme is setup to display temperature in Fahrenheit.

Menu options for all sender types

LABEL:

Choose one of a selection of labels to suit your temperature input so you can identify it easily.

TEMPERATURE UNIT:

Select whether you want the temperature to be displayed in degrees Celcius (°C) or in degrees Fahrenheit (°F).

DISPLAY MAX:

Select the maximum temperature that you want the bargraph to show. This can give you increased display resolution.

DISPLAY MIN:

Select the minimum temperature that you want the bargraph to show. This can give you increased display resolution.

LOW ALARM:

This enables or disables the temperature low alarm.

LOW ALARM:

Enter the temperature threshold for when the low alarm must be activated. Any temperature below this value will activate the alarm.

LOW CAUTION:

Enter the temperature value for the low caution. This is the upper value of the lower yellow band.

HIGH CAUTION:

Enter the temperature value for the high caution. This is the lower value of the upper yellow band.

HIGH ALARM:

This enables or disables the temperature high alarm.

HIGH ALARM:

Enter the temperature threshold for when the high alarm must be activated. Any temperature above this value will activate the alarm.

4.3.9 Calibrating the user defined pressure and Temperature Senders

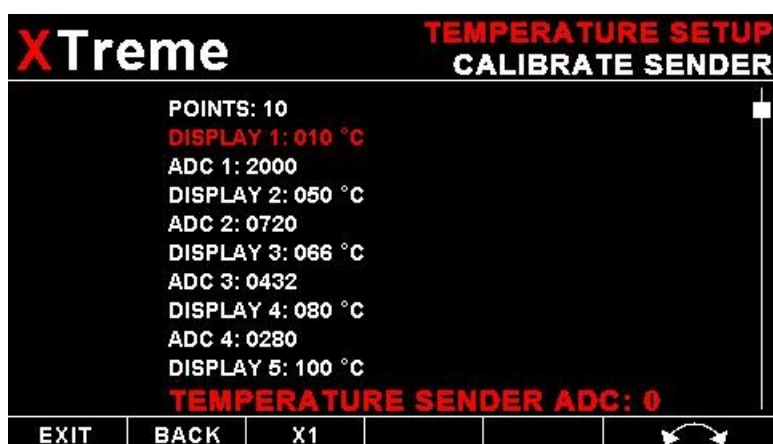

1. Enter the number of points that you want to calibrate.
2. Enter the display reading that you want to show when the sender is at that actual display reading.
3. Enter the ADC (analog to digital converter) reading that corresponds to this display reading. The ADC reading is shown at the bottom of the display if you are applying the actual stimulus from the temperature or pressure sender. You can also manually enter this value if the ADC value is known or pre-calculated.
4. Continue entering display and ADC values until all the points have been entered.
5. Verify the above calibration by checking the temperature/pressure display versus the actual applied sender stimulus.

If the “CURRENT” function is selected:

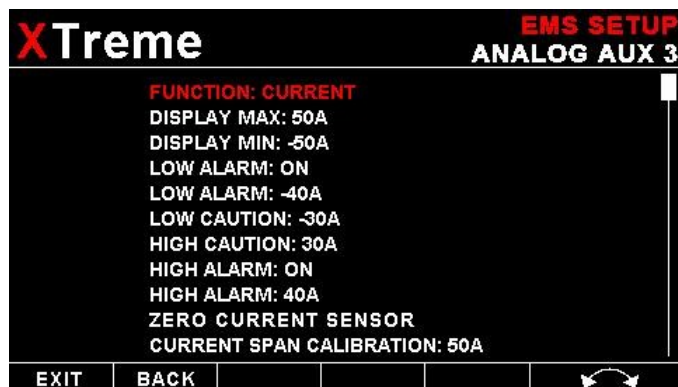

DISPLAY MAX:

Select the maximum current that you want the bargraph to show. This can give you increased display resolution.

DISPLAY MIN:

Select the minimum current that you want the bargraph to show. This can give you increased display resolution.

LOW ALARM:

This enables or disables the current low alarm.

LOW ALARM:

Enter the current threshold for when the low alarm must be activated. Any current below this value will activate the alarm.

LOW CAUTION:

Enter the current value for the low caution. This is the upper value of the lower yellow band.

HIGH CAUTION:

Enter the current value for the high caution. This is the lower value of the upper yellow band.

HIGH ALARM:

This enables or disables the current high alarm.

HIGH ALARM:

Enter the current threshold for when the high alarm must be activated. Any current above this value will activate the alarm.

ZERO CURRENT SENSOR:

Select this function to indicate to the XTreme that zero current is flowing through the MGL current monitor. This is best done with the MGL current monitor disconnected from the main current supplying conductor.

CURRENT SPAN CALIBRATION:

Enter the maximum value that your MGL current monitor can measure. This will depend on the distance and the method that is used to attach the MGL current monitor to the main current supplying conductor. It will be best if a multimeter can be inserted in series with the current supplying conductor and the span calibration adjusted until the XTreme matches that of the multimeter. Please see the MGL current monitor document for more information.

4.3.10 Volts Setup

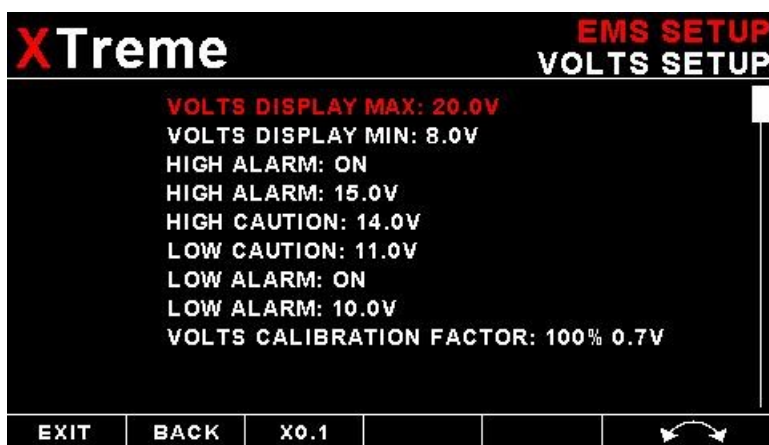

VOLTS DISPLAY MAX:

Select the maximum value that you want the volts bargraph in the EMS display to show. This can give you increased display resolution.

VOLTS DISPLAY MIN:

Select the minimum value that you want the volts bargraph in the EMS display to show. This can give you increased display resolution.

HIGH ALARM:

This enables or disables the volts high alarm.

HIGH ALARM:

Enter the voltage threshold for when the high alarm must be activated. Any voltage above this value will activate the alarm.

HIGH CAUTION:

Enter the voltage for the high caution. This is the lower value of the upper yellow band.

LOW CAUTION:

Enter the voltage for the low caution. This is the upper value of the lower yellow band.

LOW ALARM:

This enables or disables the volts low alarm.

LOW ALARM:

Enter the voltage threshold for when the low alarm must be activated. Any voltage below this value will activate the alarm.

VOLTS CALIBRATION FACTOR:

Measure the battery voltage with a multimeter and then adjust this value to match that of the multimeters volts reading.

4.3.11 OAT Setup

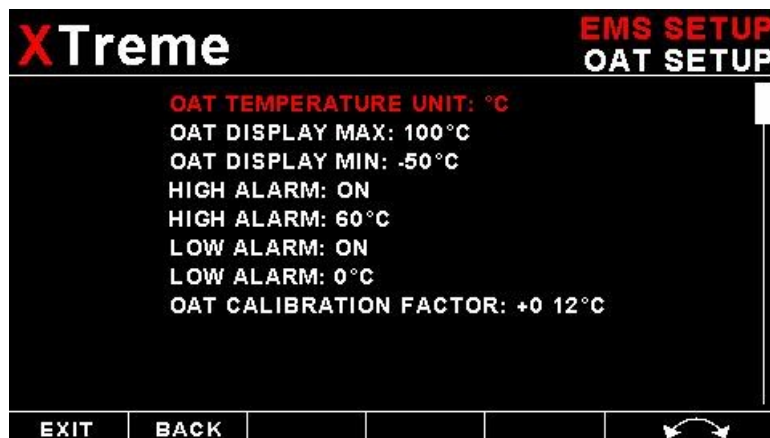

OAT TEMPERATURE UNIT:

Select whether you want the OAT to be displayed in degrees Celsius (°C) or in degrees Fahrenheit (°F).

OAT DISPLAY MAX:

Select the maximum temperature that you want the OAT bargraph in the EMS display to show. This can give you increased display resolution.

OAT DISPLAY MIN:

Select the minimum temperature that you want the OAT bargraph in the EMS display to show. This can give you increased display resolution.

HIGH ALARM:

This enables or disables the OAT high alarm.

HIGH ALARM:

Enter the temperature threshold for when the high alarm must be activated. Any temperature above this value will activate the alarm.

HIGH CAUTION:

Enter the temperature for the high caution. This is the lower value of the upper yellow band.

LOW CAUTION:

Enter the temperature for the low caution. This is the upper value of the lower yellow band.

LOW ALARM:

This enables or disables the OAT low alarm.

LOW ALARM:

Enter the temperature threshold for when the low alarm must be activated. Any temperature below this value will activate the alarm.

OAT CALIBRATION FACTOR:

During the factory calibration a factor has been determined and entered here that will give you an accurate OAT reading. If you find this value is incorrect then adjust the calibration factor until the XTremes OAT matches that of a precision thermometer. Calibration can only be done in Celcius (°C).

4.3.12 CO Monitor Carbon Monoxide Setup



The CO Monitor Carbon Monoxide menu option allows the pilot to enable the CO Guardians Carbon Monoxide detector. The XTreme-EMS will display the carbon monoxide value on the EMS display as well as enable the carbon monoxide warning alarm. Please see the relevant CO Guardian detector manuals for more information.

CO Monitor:

Select which CO Monitor you are using. Select "None" to disable the CO display.

RESET CO GUARDIAN:

This will reset the CO Guardian Carbon Monoxide detector, perform a self test and then will re-enable the CO Guardian Carbon Monoxide detector.



4.4 GPS Setup

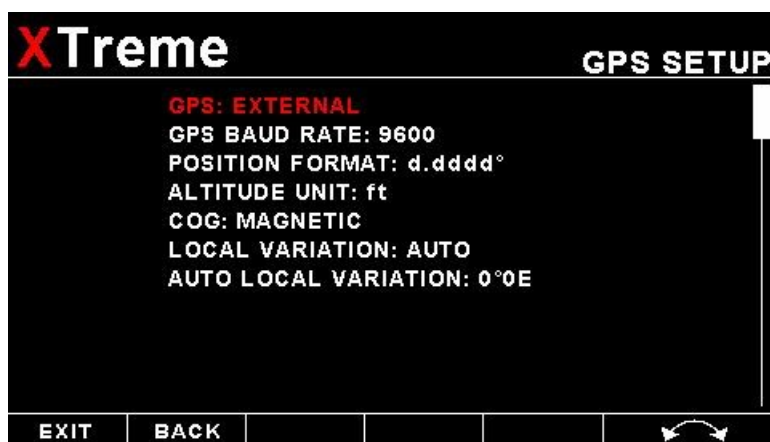

GPS:

Select "OFF" to disable the GPS information screen or select "EXTERNAL" if you have an external NMEA compatible GPS connected to the XTreme-EMS.

If an external GPS is used then it must output the following NMEA sentences

- GGA - Global positioning system fix data
- RMC – Recommended minimum specific GNSS data
- GSA – GNSS DOP and active satellites
- GSV – GNSS satellites in view

NMEA stands for the National Marine Electronics Association. For more information please visit www.nmea.org.

GPS BAUD RATE:

Select the baud rate to match the external GPS receiver you are using.

POSITION FORMAT:

Select the display format of the GPS latitude and longitude.

ALTITUDE UNIT:

Select the unit of the altitude display.

COG:

Select if you want the COG to be related to true or magnetic north.

LOCAL VARIATION:

Select "AUTO" to allow the XTreme-EMS to automatically calculate the local variation or "MANUAL" for manual local variation input.

AUTO LOCAL VARIATION:

This item displays the calculated local magnetic variation. The XTreme-EMS will calculate the local variation every 10 minutes if a valid 2D or 3D GPS fix is obtained.

MANUAL LOCAL VARIATION:

This item allows the pilot to manually enter his local variation.

4.5 Timers Setup



HOBBS MINIMUM RPM:

Enter the RPM limit in which the Hobbs timer/Maintenance timer must start incrementing.

SET HOBBS TIME:

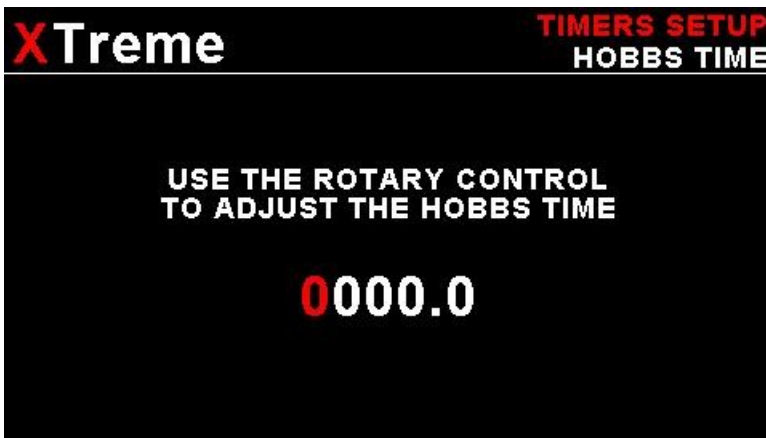

This function allows you to set the engine Hobbs meter to any value. Typically, you would use this function to set the Hobbs meter to the current known engine time. Use the rotary control to change the value. Press the rotary control to accept and exit the menu option. If the Hobbs code is set to another value beside zero, then the pilot will be prompted to enter the Hobbs access code before allowing him to change the Hobbs time. This feature is useful for chartered and flying school planes.

CHANGE HOBBS CODE:

This menu option allows you to change the Hobbs access code. You will first be prompted to enter the current code followed by entering in a new code followed by re-entering the new code. If the new code and the re-entered code is the same, then the Hobbs access code will be changed. Default code is 0000.

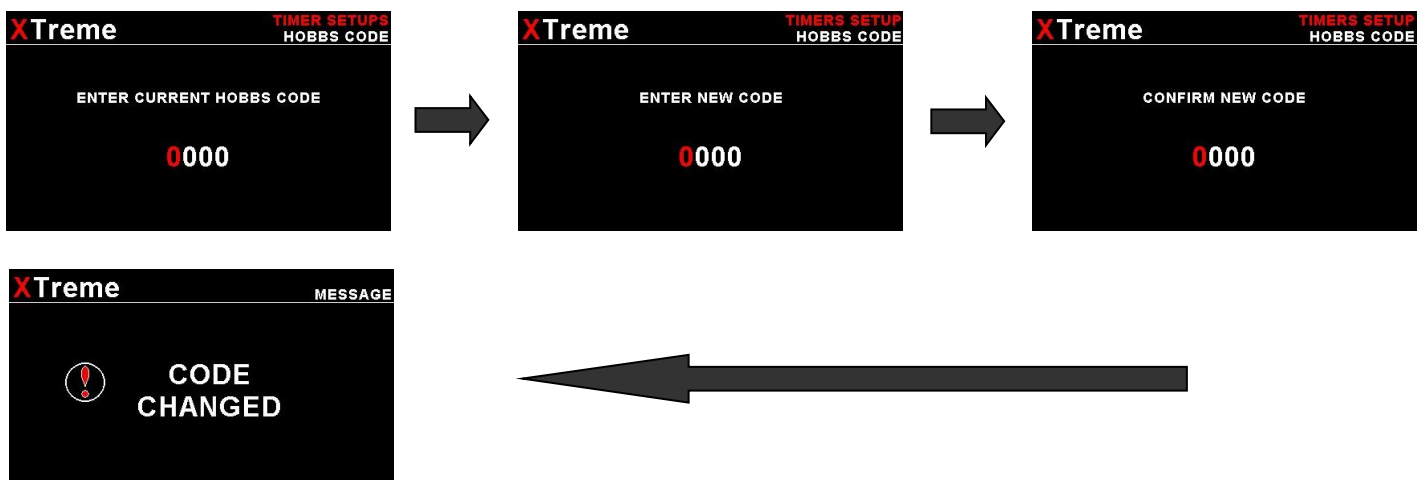

SET MAINTENANCE TIMER:

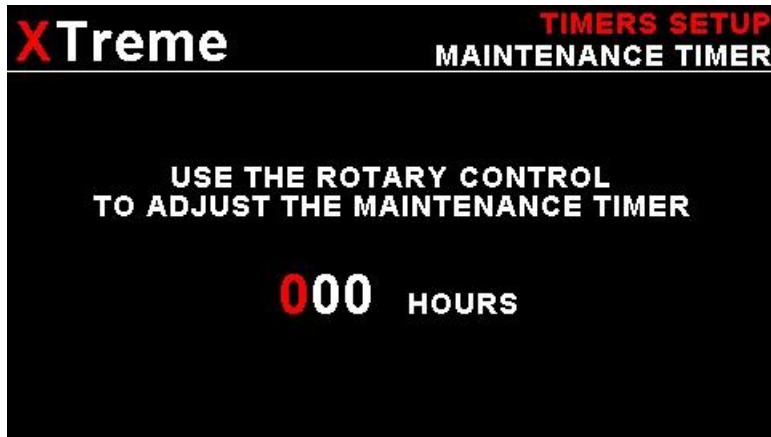

These timers allow you to keep track of engine maintenance interval. Set the timer when you have serviced your engine. A typical time might be 50 hours. This function allows you to set an engine maintenance timer. This timer is set in engine hours and it will count down to zero when the engine RPM is greater then the "HOBBS MINIMUM RPM". A good use for this function is to set the hours until your next spark plug change or engine inspection. Use the rotary control to change the value.

UTC OFFSET:

Enter the UTC offset for your location. The UTC offset can be adjust in half an hour increments.

RTC SOURCE:

Select if you want the RTC UTC time to come from the GPS receiver or the internal RTC. Both real time clocks are powered by an internal 3V lithium coin cell battery. The internal battery can be replaced by unscrewing the 5 screws holding the back and front enclosures together as well as the 2 screws next to the D15 connector. Delicately slide out the electronics and replace the battery. The battery is a CR2032 coin cell.

SET UTC DATE & TIME:



Use the rotary control to set the UTC date & time in the internal RTC.

4.6 Data Recording Setup



The XTreme-EMS has the ability to act as a black box recorder recording flight data directly onto an inserted SD card for later playback and investigation using the MGL Avionics Black Box viewer program. See the Black box viewer documents for further information. The Black box viewer can also convert the data into other file formats such as:

- KML: Keyhole Markup Language / Google Earth
- CSV: Comma-Separated Variable
- IGC: FAI Gliding commission

The XTreme-EMS records the engine data as well as the GPS data (If an external GPS receiver is available) once per second WHEN A VALID FLIGHT IS DETECTED (AUTOMATIC OR MANUAL FLIGHT DETECT MODE).

CREATE RECORDING FILE ON SD CARD:

Selecting this menu option will create a file on the SD card (If inserted and not write protected) called enigma.rec with a fixed file size of 10MB. The reason behind the fixed file size of the recording file has to do with limited write cycles of the SD card and the instability of the MS-DOS file system. With a fixed file size, the XTreme-EMS never has to write to either the directory structure or FAT tables of the SD card eliminating wear of the card or possible data corruption. Once the recording file has been filled, the recording continues at the start of the file again, overwriting the oldest data in the file.

The file size is large enough to record 5-20 hours of data depending on what data is recorded.

DATA RECORDING ON:

Selecting "ON" will enable the data recording functionality.

4.6.1 Examples of the exported flight data using CSV format and the KML format

EnigmaCSV - OpenOffice.org Calc

File Edit View Insert Format Tools Data Window Help

Arial 10 B / U

125 f(x) Σ =

	A	B	C	D	E	F	G	H	I	J	K	L	M	N	O	
1	Date Time	Alt	Baro	ASI	TAS	VSI	Glide S	RRPM	main V	bckg V	Amps	AOA	OAT	ERPM	RFL1	RF
2	PFD	PFD	PFD	PFD	PFD	PFD	PFD	PFD	PFD	PFD	PFD	PFD	PFD	RDAC 1	RDAC 1	RC
3	MM/dd/yy hh:mm:ss	feet	mB	m/h	m/h	ft/m	none	RPM	V	V	A	none	degC	RPM	none	no
4	01/01/2000 00:49:20	-75	3356	31	31	22	99.9	32768	11.3	10.8	0	0	14	4440	2043	
5	01/01/2000 00:49:22	-73	3356	34	34	0	0	32768	11.4	10.9	0	0	14	4402	2043	
6	01/01/2000 00:49:24	-73	3357	37	37	-11	-99.9	32768	11.4	10.9	0	0	14	4167	2043	
7	01/01/2000 00:49:26	-74	3356	40	40	-22	-99.9	32768	11.4	10.9	0	0	14	4317	2043	
8	01/01/2000 00:49:28	-71	3355	42	42	-11	-99.9	32768	11.2	10.7	0	0	14	4341	2043	
9	01/01/2000 00:49:30	-70	3356	44	44	0	0	32768	11.3	10.8	0	0	14	4504	2043	
10	01/01/2000 00:49:32	-68	3356	46	46	11	99.9	32768	11.3	10.9	0	0	14	4504	2043	
11	01/01/2000 00:49:34	-66	3355	47	47	0	0	32768	11.4	10.9	0	0	14	4427	2043	
12	01/01/2000 00:49:36	-67	3355	48	48	-11	-99.9	32768	11.3	10.8	0	0	14	4504	2043	
13	01/01/2000 00:49:38	-67	3355	50	50	-11	-99.9	32768	11.3	10.8	0	0	14	4491	2043	
14	01/01/2000 00:49:40	-66	3356	51	51	-11	-99.9	32768	11.4	10.9	0	0	14	4491	2043	
15	01/01/2000 00:49:48	-71	3356	43	43	22	99.9	32768	11.4	10.9	0	0	14	4112	2043	
16	01/01/2000 00:49:50	-70	3356	43	43	45	84	32768	11.4	10.9	0	0	14	4201	2043	
17	01/01/2000 00:49:52	-70	3355	44	44	22	99.9	32768	11.4	10.9	0	0	14	4212	2043	
18																
19																
20																

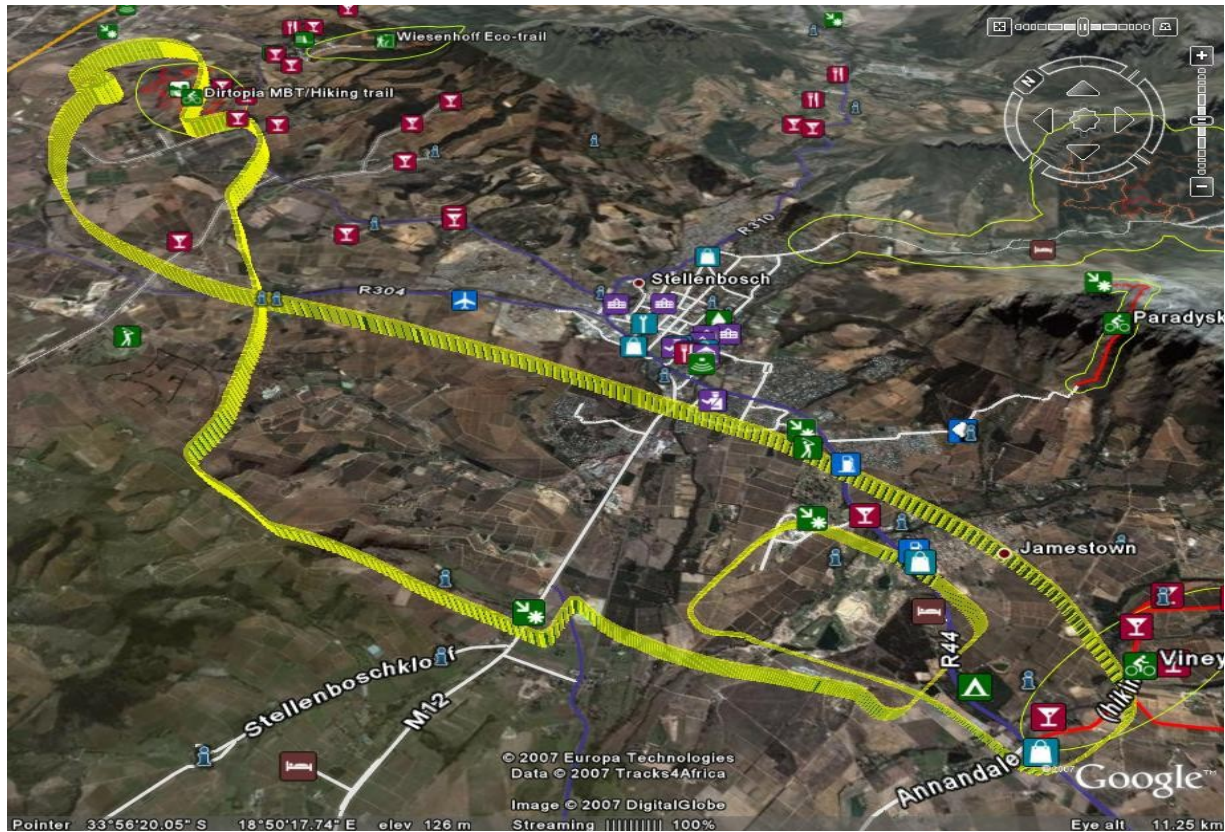

4.7 Miscellaneous Setup



AIRCRAFT REGISTRATION:



Enter your aircraft registration. A maximum of 8 characters can be entered. The aircraft registration is displayed on the start up (Splash) screen.

SAVE SETTINGS TO SD CARD:

Select this option to save all the XTreme-EMS settings to the SD card. This is useful when setting up the instrument on the PC simulator and then later transferring the settings on the instrument itself. A file called "XTREME.EMS" will be created in the root directory of the SD card.

RECALL SETTINGS FROM SD CARD:

Select this option to recall all the XTreme-EMS settings from the SD card. This is useful when setting up the instrument on the PC simulator and then later transferring the settings to the instrument itself. The settings will be loaded from a file called "XTREME.EMS" in the root directory of the SD card.

4.8 ADC Values

These values are mainly used for debugging purposes. Contact the MGL factory or your local dealer for more information.

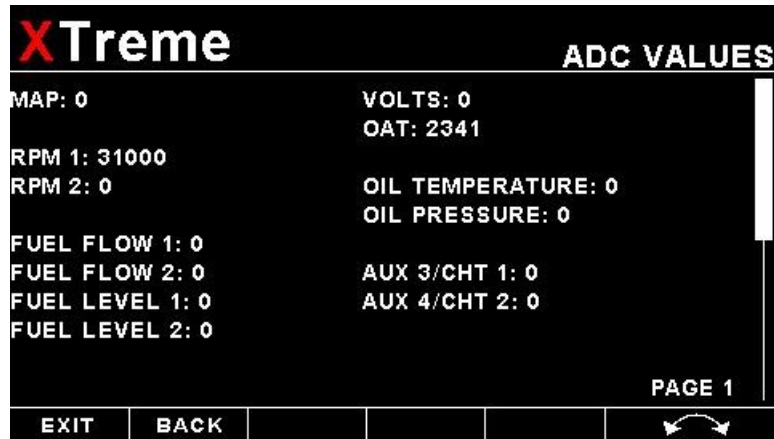

5 Startup (Splash) Screen

Creating your own Startup (Splash) Screen

You will need:

- A bitmap picture of your choice (*.BMP, 480x272 pixel resolution)
- The Enigma BMP to MIF converter tool (can be downloaded free of charge from <http://www.mglavionics.co.za> or can be found on the XTreme SD card).

The Enigma BMP to MIF program is used to convert images in Windows BMP format to Enigma MIF format. You can use this program to make your own startup screen (Splash screen) and graphic information display screens. The color depth is limited to Enigmas 256 colors.

Run the Enigma BMP image to MIF format converter program.

Load an image file (and remember the location), select the resolution as width(480) and height (272) and press the process button. The new MIF image will be located in the same directory as the source (BMP) file.

If the original file was not named Splash.BMP, rename the new *.MIF file to Splash.MIF, and copy the Splash.MIF file into the root directory of your SD card.

The picture will be displayed when the unit is powered up.

6 Loading factory default settings

Press and hold the left and right most soft keys simultaneously on power up to load default factory settings. The following message will be displayed:

**LOADING DEFAULT
SETTINGS**

7 Alarm condition

**ALARM
RPM HIGH 879**

If an alarm condition occurs the following will happen:

- The item causing the alarm condition will flash on the screen
- An alarm warning message will be displayed on the screen
- An external alarm switch will close

The alarm warning message and switch closure will remain until any button is pressed or until the condition(s) that activated the alarm no longer exist.

The alarm output can be used to switch an external alarm indicator. The external alarm switch is an open collector transistor switch to ground with a maximum rating of 0.5A DC. It is possible to wire the alarm contacts of several Stratomaster instruments in parallel should this be desired.

To avoid false activation of the alarms, the alarm function is only active 10 seconds after the instrument has powered up.

8 Cleaning

The unit should not be cleaned with any abrasive substances. The screen is very sensitive to certain cleaning materials and should only be cleaned using a clean, damp cloth.

Warning: The XTreme-EMS is not waterproof. Serious damage could occur if the unit is exposed to water and/or spray jets.

9 XTreme-EMS Specifications

Operating Temperature Range	-10°C to 50°C (14°F to 122°F)
Storage Temperature Range	-20°C to 80°C (-4°F to 176°F)
Humidity	<85% non-condensing
Power Supply	8 to 30Vdc SMPS (switch mode power supply) with built in 33V over voltage and reverse voltage protection
Current Consumption	Approx. 130mA @ 13.8V
Display	4.3" 480x272 pixel, 600 nits active matrix TFT LCD (Sunlight Readable). LED backlight is user adjustable.
Dimensions	see section 12 for dimensional drawings
ADC	12 bits 100ksps
Enclosure	3 1/8" ABS, black in color, front mounting. See XTreme-EMS dimensional drawing
Weight	Approx. 250 grams (XTreme-EMS unit only)
Alarm contact current rating	Open collector transistor switch to ground. Maximum rating 0.5A DC
Non-volatile memory storage	100000 write cycles
Warm up time	10 minutes

10 Installation

10.1 XTreme-EMS General Connection Diagram

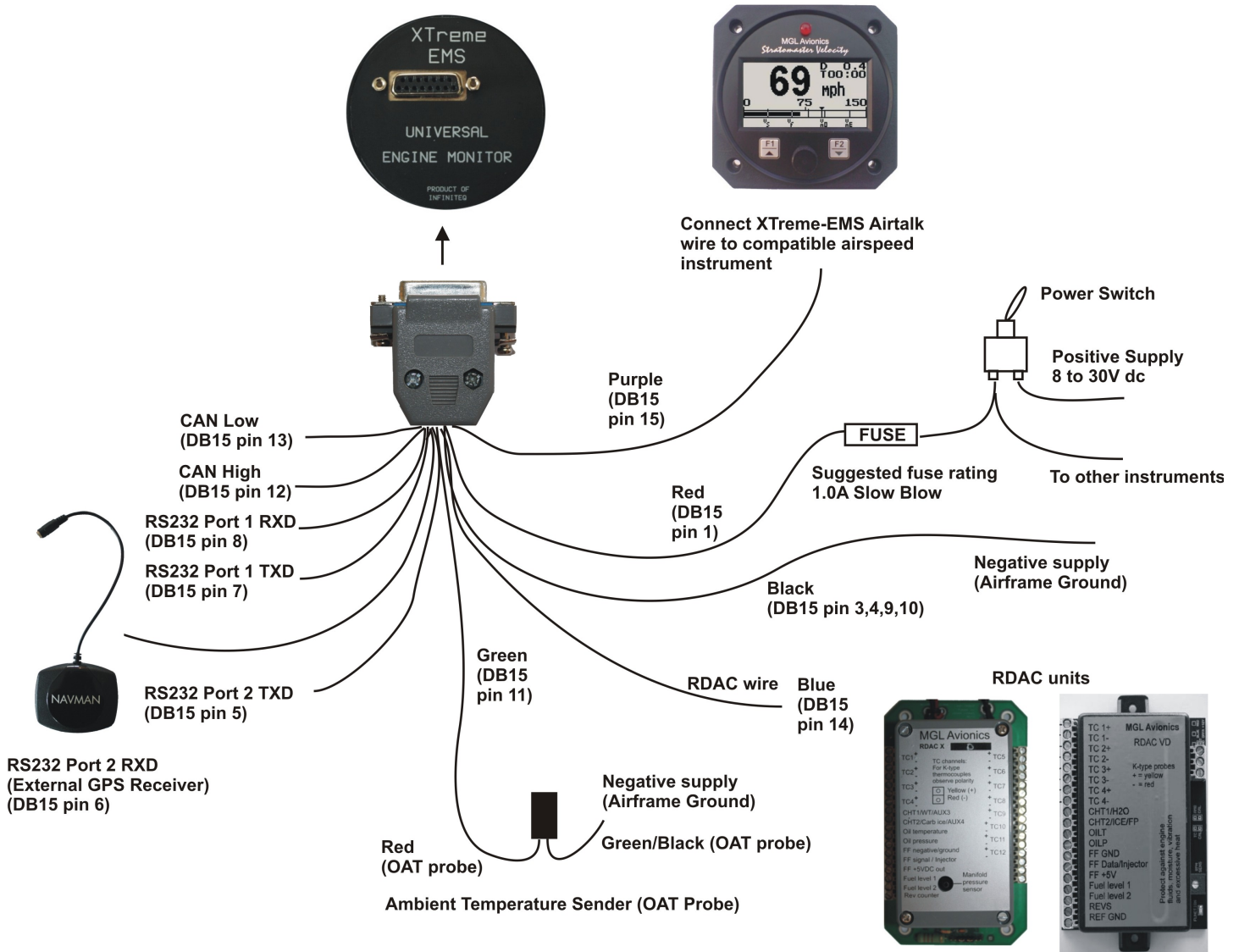

The use of an external 1A fuse is recommended. Connect the supply terminals to your aircraft's power supply. The XTreme-EMS can be used on both 12V and 24V without the use of any pre-regulators. Ensure that the supply voltage will not drop below 8V during operation as this may result in incorrect readings.

Please see MGL Avionics RDAC documentation for installation and usage.

10.2 Xtreme-EMS DB15 Cable connections

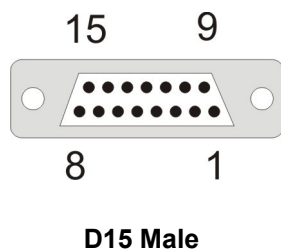

DB 15 Pin	Color	Function
1	Red	8-30Vdc power
2	White	Alarm Output
3,4,9,10	Black	Ground
5	NC	RS232 Port 2 Transmit
6	NC	RS232 Port 2 Receive
7	NC	RS232 Port 1 Transmit
8	NC	RS232 Port 1 Receive
11	Green	OAT Probe
12	NC	CAN High
13	NC	CAN Low
14	Blue	RDAC Signal
15	Purple	Airtalk

NC=Not Connected

The XTreme-EMS has a D15 Female connector. The connecting cable must have a D15 male connector attached to it.

11 Firmware upgrades

The XTreme-EMS' firmware can be upgraded in the field to the latest version via the SD card. This will keep your XTreme-EMS up to date with bug fixes and new features.

The name of the firmware file must be called XTREME.FW and it must reside in the root directory of the SD card. When the XTreme-EMS powers up it will first look at the SD card to see whether the file exists, if it does then it will prompt the user to upgrade the firmware. Use the soft keys at the bottom to select whether to upgrade to the new firmware or to exit the firmware upgrade feature. The XTreme-EMS also provides a soft key to delete the XTREME.FW file from the SD card to avoid removing the SD card and deleting it with a PC.

If the file does not exist, then the firmware upgrade function is bypassed and the XTreme-EMS' main program is executed. Please check <http://www.mglavionics.co.za/XTreme.html> regularly for the latest firmware releases.



12 XTreme-EMS Dimensions

12.1 Front view

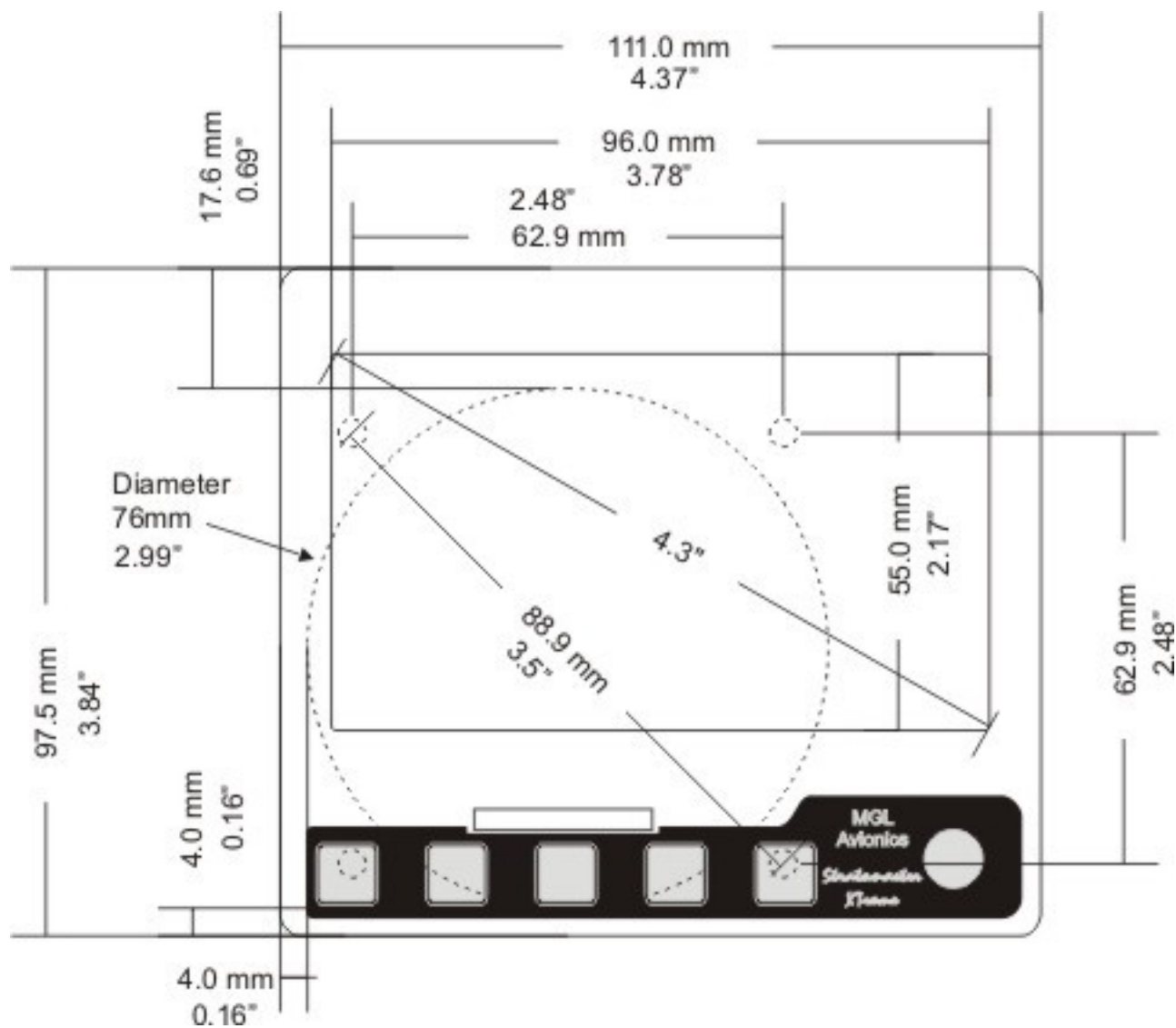

12.2 Side view

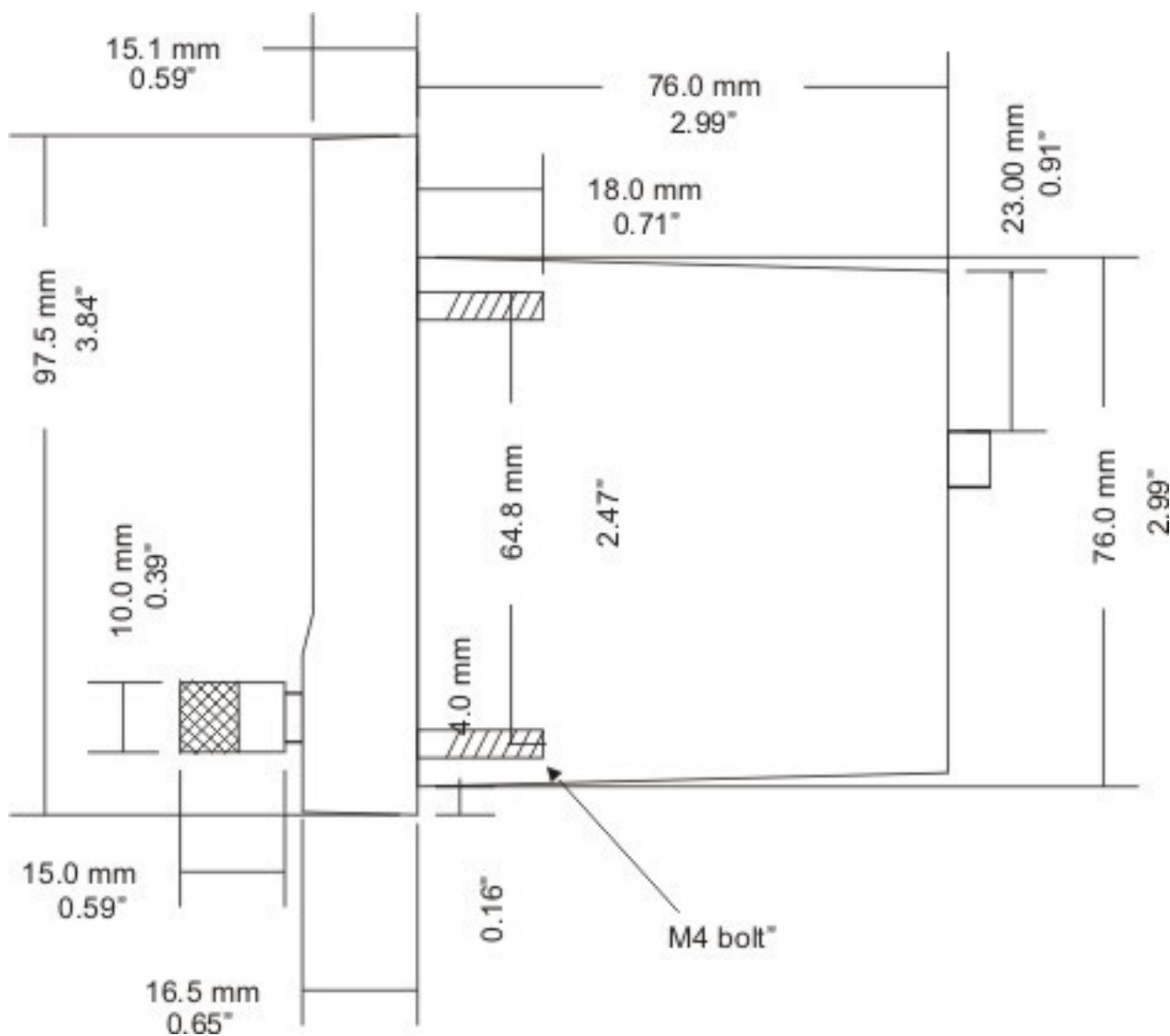

12.3 Top view

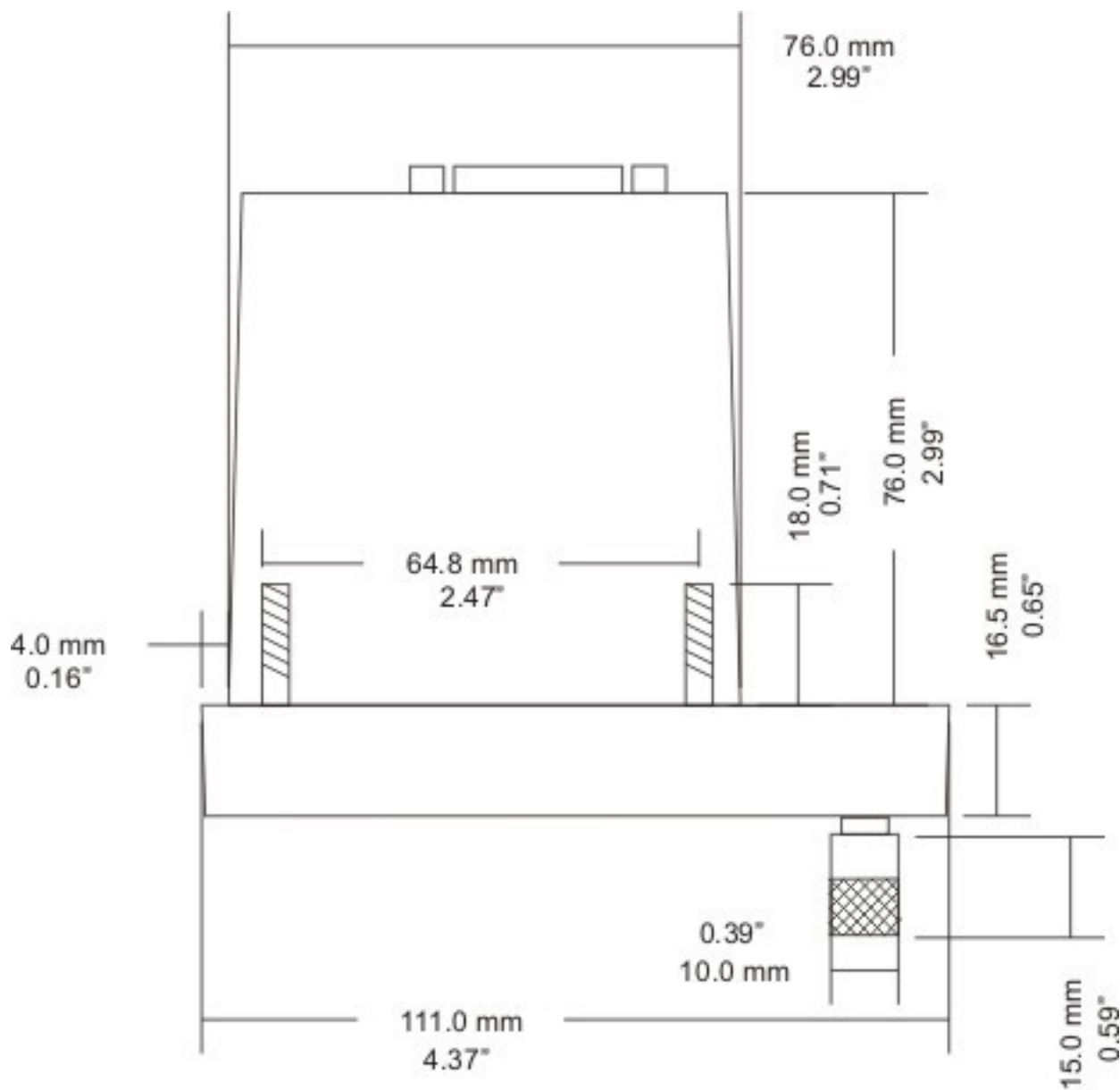

13 Warranty

This product carries a warranty for a period of one year from date of purchase against faulty workmanship or defective materials, provided there is no evidence that the unit has been mishandled or misused. Warranty is limited to the replacement of faulty components and includes the cost of labor. **Shipping costs are for the account of the purchaser.**

Note: Product warranty excludes damages caused by unprotected, unsuitable or incorrectly wired electrical supplies and or sensors, and damage caused by inductive loads.

14 Disclaimer

Operation of this instrument is the sole responsibility of the purchaser of the unit. The user must make themselves familiar with the operation of this instrument and the effect of any possible failure or malfunction.

This instrument is not certified by the FAA. Fitting of this instrument to certified aircraft is subject to the rules and conditions pertaining to such in your country. Please check with your local aviation authorities if in doubt. This instrument is intended for ultralight, microlight, home built and experimental aircraft. Operation of this instrument is the sole responsibility of the pilot in command (PIC) of the aircraft. This person must be proficient and carry a valid and relevant pilot's license. This person has to make themselves familiar with the operation of this instrument and the effect of any possible failure or malfunction. Under no circumstances does the manufacturer condone usage of this instrument for IFR flights.

The manufacturer reserves the right to alter any specification without notice.